



1510 Side Mounted Level Switch

General Instructions

The SOR® 1510 Level Switch mounts into the side of a vessel. Electric switching action is provided by the float moving a magnet into the field of a hermetically sealed reed switch capsule.

The unit may be mounted for either high or low liquid level alarm by rotating the switch body to the proper position. The body wrench flats provide for ease of rotation and proper positioning. See decal on housing.

Before Installation of the Level Switch:

- Inspect the unit for any shipment damage.
- Check for mechanical clearance of the float. Float must move freely without binding throughout its stroke.
- Use an acceptable thread compound when installing unit to ensure a leak-free fit and to avoid thread galling.
- To achieve required function, install the unit according to the nameplate instructions shown here.



NOTE: If you suspect that a product is defective, contact the factory or the SOR Representative in your area for a return authorization number (RMA). This product should only be installed by trained and competent personnel.

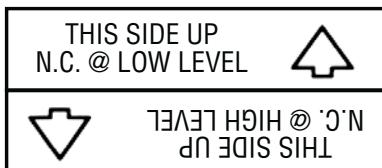

Nameplate Position for Low Level Alarm



Nameplate Position for High Level Alarm

NC - indicates circuit is closed

Design and specifications are subject to change without notice.

For latest revision, go to www.SORInc.com

Table of Contents

Installation	3
SIL Installation Instructions	3
Float Attachment	3
Dimensions	4
Electrical Connection	5
Special Conditions	5
Wiring for DPDT Relay	6
ATEX and IECEx Marking Details	6
Declaration of Conformity	7
Troubleshooting	8
Replacement Parts	8

Installation

The unit may be mounted in any of the following installation arrangements:

- 1-1/2" NPT half coupling (No full coupling).
- 2" NPT full coupling. (Use in conjunction with 2 x 1-1/2" NPT bushing as required.)
- 2" NPT pipe tee. (Use in conjunction with 2 x 1-1/2" NPT bushing as required.)
- Optional flanged mounting.
- Optional chamber mounting.

MD Remote Option (includes plunger, 20 foot cable and two crimps.)

- Screw plunger to the top of unit.
- Thread the 20' cable through the hole in plunger and create a 14 inch top loop as shown below.
- At the bottom of the cable, a second loop can be created as a handle for actuation at the desired length.

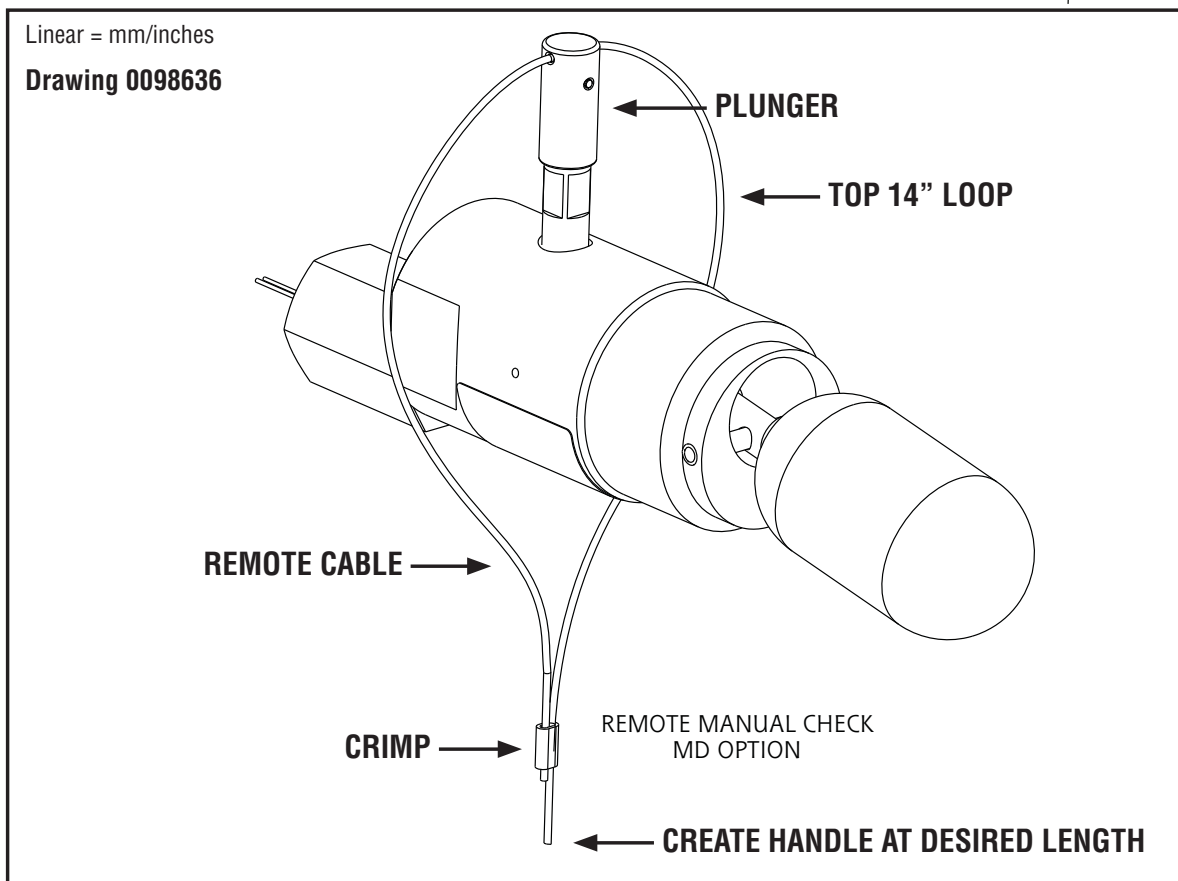

Safety Integrity Level (SIL) Installation Requirements

The SOR pressure switches have been evaluated as Type-A safety related hardware. To meet the necessary installation requirements for the SIL system, the following information must be utilized:

- Proof Test Interval shall be one year.
- Units may only be installed for use in Low Demand Mode.
- Products have a HFT (Hardware Fault Tolerance) of 0, and were evaluated in a 1oo1 (one out of one) configuration.

Form 1538 (03.12) ©2012 SOR Inc.

Float Attachment (Series 1500 with Flange)

- 1 Place two drops of Loctite 271 inside the threaded hole of the float.
- 2 Thread the float onto the set screw and hand-tighten.

NOTE: Do not remove the set screw as it secures the pivot arm to the shaft.

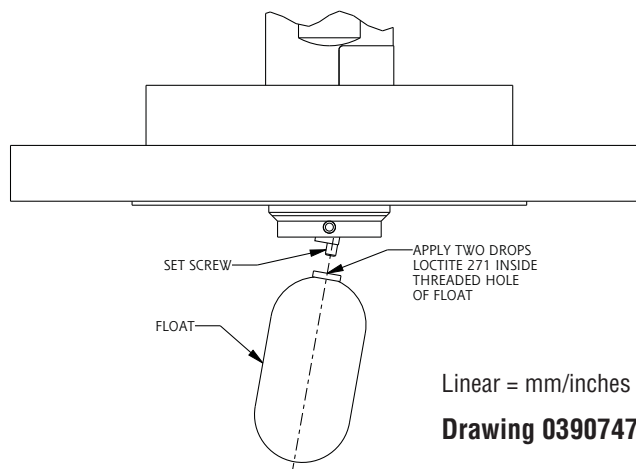

Dimensions

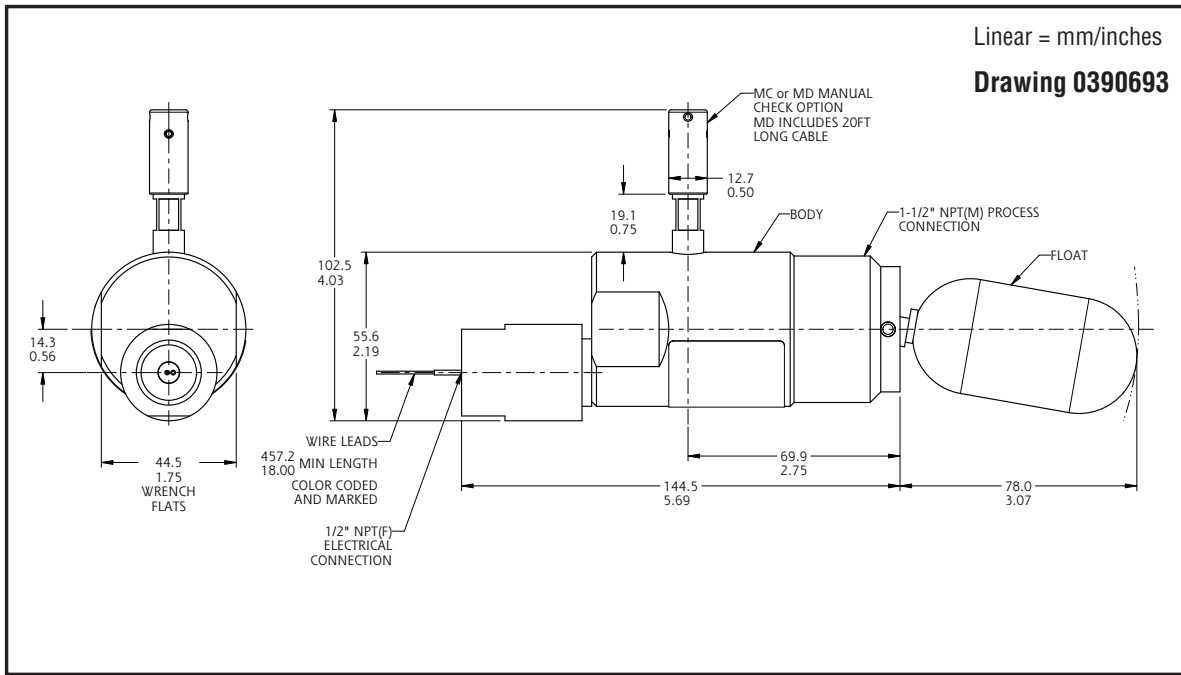

With CK Accessory – ATEX and IECEx dual approved:

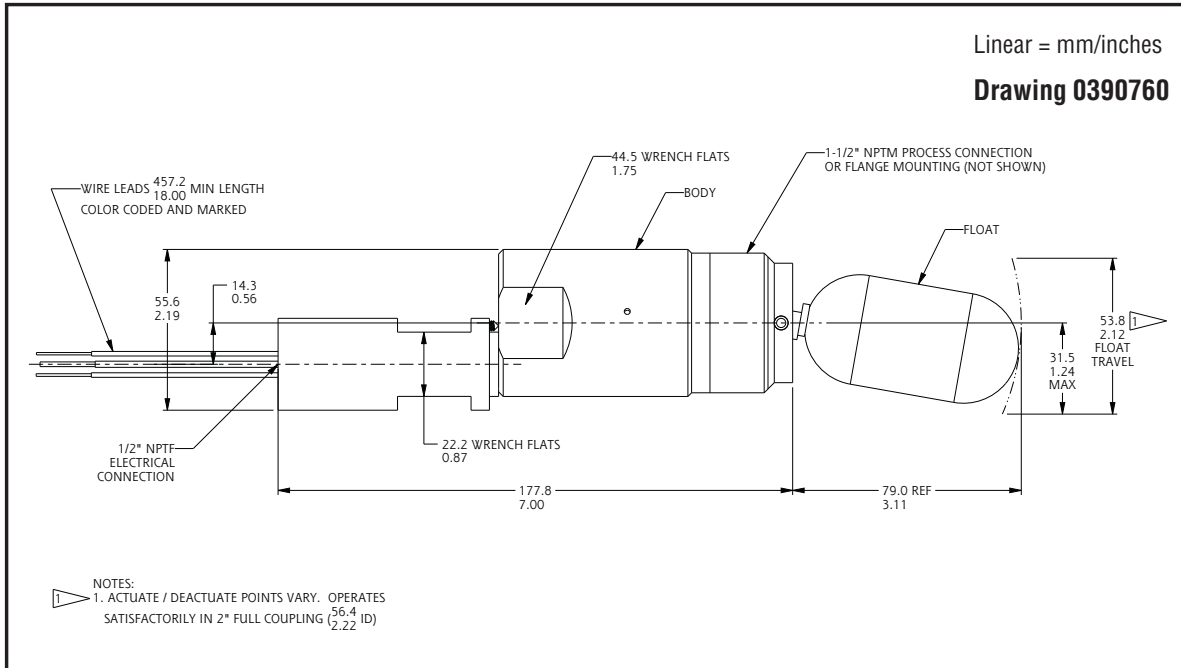

Dimensions are for reference only. Contact the factory for certified drawings for a particular model number.

Electrical Connection

Ensure that the wiring conforms to all applicable local and national electrical codes and install unit(s) according to relevant national and local safety codes.

Electrical connection is free wire leads with a 1/2" NPT(F) conduit connection. Use two wrenches — one to hold the hex conduit connection, the other to tighten conduit fitting. Switching element is a hermetically sealed reed switch.

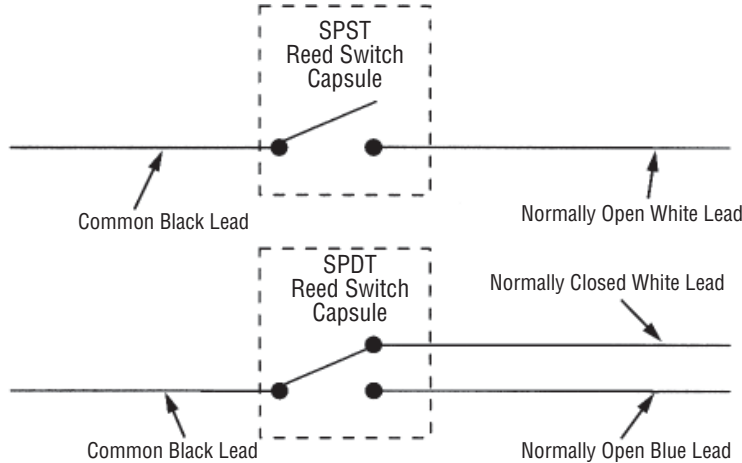

Do not exceed catalog stated electrical ratings. Improper current input to switch will cause permanent damage to contacts.

Special Conditions for Safe Use

This apparatus may have a combined nameplate which carries multiple approvals (intrinsically safe and flameproof). The equipment should be marked as to which protection method it is installed as and shall not be changed or utilized in any other means than was originally marked by the end user.

When marked and installed as Ex i equipment, the permanently attached leads must be suitably protected against mechanical damage and terminated in a suitable junction box or terminal facility having a degree of protection at least IP20.

When marked and installed as Ex d equipment, the permanently attached leads must be suitably protected against mechanical damage and terminated in a suitable junction box or terminal facility.

Wiring for DPDT Relay

For Type 1510 Level Switches equipped with DPDT relays, a wiring schematic and pin position schematic is shown below. When the 1510 is actuated, the coil will energize and “make” both NO1 and NO2 while it will “break” NC1 and NC2. This provides a DPDT circuit.

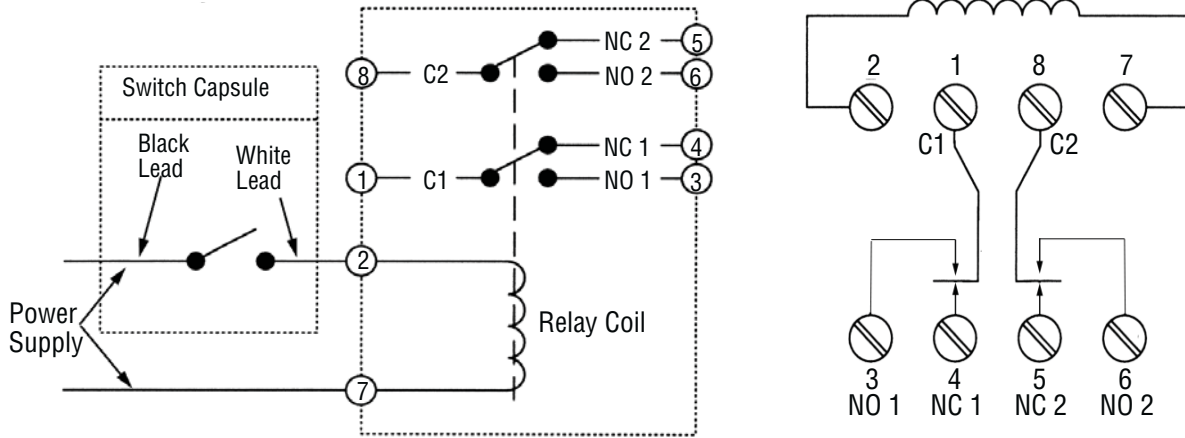

ATEX and IECEx Marking Details

For ATEX and IECEx Certified Models

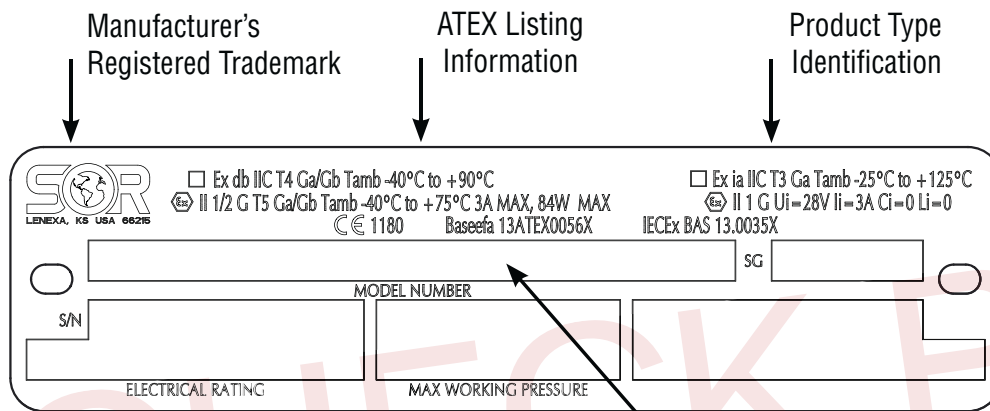

Drawing 0720554

Product Model Identification

Standards Assessed To

ATEX Certification: EN 60079-0: 2012 & A11: 2013 & EN 60079-11: 2012
 EN 60079-0: 2012 & A11: 2013, EN 60079-1: 2014
 EN 60079-11: 2012 & EN 60079-26: 2015

IECEx Certification: IEC 60079-0: 2011, IEC 60079-1: 2007-04,
 IEC 60079-11: 2011 & IEC 60079-25: 2010-02
 IEC 60079-0: 2004 & IEC 60079-11: 1999

Declaration of Conformity

For ATEX Certified Models

EC Declaration of Conformity



Product Type 1500 Electric Switches

Manufacturer SOR Inc., 14685 West 105th Street, Lenexa, Kansas 66215-2003
United States of America

Date of Issue December 18, 2017

We declare that the above products conform to the following specifications and directives

ATEX Directive (2014/34/EU) Equipment Intended for use in Potentially Explosive Atmospheres
EN 60079-0: 2012 + A11:2013 & EN 60079-11: 2012
IEC 60079-0: 2007 & IEC 60079-11: 2006
EN 60079-0: 2012 + A11:2013, EN 60079-1: 2014
EN 60079-11: 2012 & EN 60079-26: 2015
IEC 60079-0: 2011, IEC 60079-1: 2007,
IEC 60079-11: 2011 & IEC 60079-25: 2010

Carries the Marking

II 1 G Ex ia IIC Ga T3 (-40°C ≤ Ta ≤ +125°C) or T3 (-25°C ≤ Ta ≤ +125°C)	IECEX Marking Ex ia IIC Ga T3 (-40°C ≤ Ta ≤ +125°C) or T3 (-25°C ≤ Ta ≤ +125°C)
II 2 G Ex db IIC Ga/Gb T4 (-40°C ≤ Ta ≤ +90°C) or T5 (-40°C ≤ Ta ≤ +75°C)	Ex db IIC Ga/Gb T4 (-40°C ≤ Ta ≤ +90°C) or T5 (-40°C ≤ Ta ≤ +75°C)

Reference Documents

EC-Type Examination Certificate
Baseefa06ATEX0271X, IECEX BAS06.0063X
Issued January 12, 2007

Baseefa13ATEX0056X, IECEX BAS13.0035X
Issued July 26, 2013

ATEX Notified Body **SGS Baseefa Ltd.** (Notified Body No. 1180)
Rockhead Business Park, Staden Lane,
Buxton, Derbyshire SK17 9RZ, United Kingdom
Baseefa Customer Reference No. 1021

Person Responsible Michael J. Bequette (VP of Engineering)

Michael J. Bequette

Engineered to Order with Off-the-Shelf Speed



14685 West 105th Street, Lenexa, KS 66215-2003
913-888-2630 • 800-676-6794 USA • 913-888-0767 FAX

Form 1385 (12.17) SOR Inc.

Troubleshooting

Symptom	Probable Cause
Float in actuated position but no output signal.	<ul style="list-style-type: none"> ■ No power supply. ■ Switch damaged. (Replace.)
Float in de-actuated position but still receiving an output signal.	<ul style="list-style-type: none"> ■ Switch damaged. (Replace.)
Control will not function when installed but operates when removed from process connection.	<ul style="list-style-type: none"> ■ Inadequate float travel. Float travel restricted by mounting nozzle. See Mounting Requirements.
Liquid in vessel at the actuation level but unit does not respond.	<ul style="list-style-type: none"> ■ Leaky or collapsed float. (Replace.) ■ Liquid specific gravity too low. ■ Float stem bound up or dirty. (Clean.)

Replacement Parts

Part Number	Description
3130-052	316SS Float Assembly
3130-106	W9 - SPST Hermetically Sealed Switch Capsule
3130-245	W1 - SPDT Hermetically Sealed Switch Capsule
3130-259	W1 - SPDT Switch/Conduit Connection Assembly (CK Option Only)
3130-107	L9 - SPST Hermetically Sealed Switch Capsule
3130-244	L1 - SPDT Hermetically Sealed Switch Capsule
3130-260	L1 - SPDT Switch/Conduit Connection Assembly (CK Option Only)
9227-028	MC Manual Check Assembly for 1 1/2" NPT Body*
9227-029	MD Manual Check Assembly for 1 1/2" NPT Body*
9227-024	MC Manual Check Assembly for 2" NPT Body*
9227-025	MD Manual Check Assembly for 2" NPT Body*
3130-040	20' Remote Cable with two cable crimps, for use with MC or MD accessory only.

* Unit must have originally been supplied with MC or MD option.



SORInc.com

14685 West 105th Street, Lenexa, KS 66215 ■ 913-888-2630 ■ 800-676-6794 USA ■ Fax 913-888-0767