

# INDELAC

CONTROLS, INC.

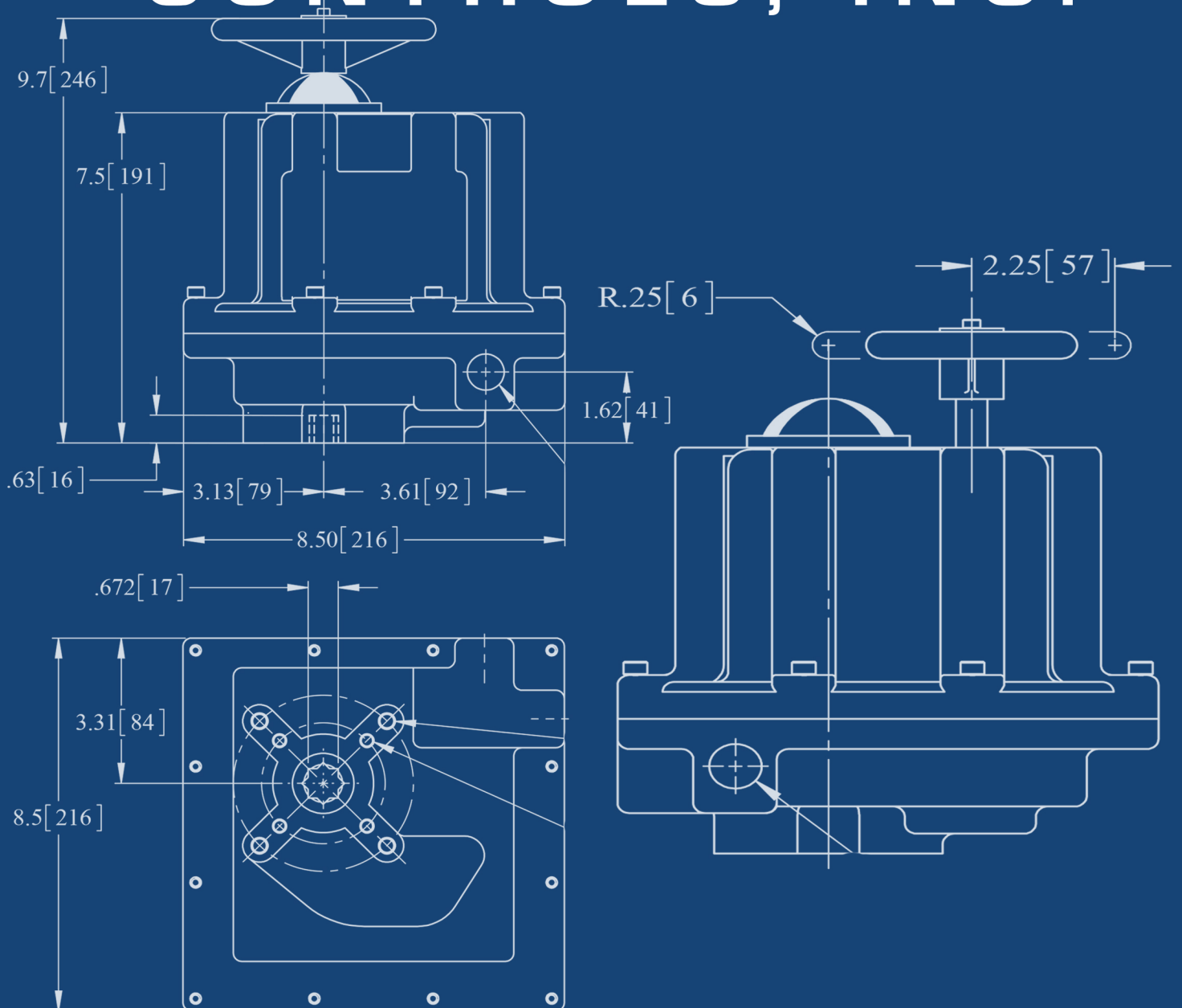

## ELECTRIC ACTUATOR Modulating AC Voltage

Installation, Operation & Maintenance Manual



**INTRODUCTION:**

Thank you for selecting Indelac Controls, Inc. (ICI) for your valve or damper automation requirement. We at ICI are proud of our products and feel confident they will meet or exceed your expectations of quality and reliability.

Every precaution has been taken to insure that your equipment will arrive undamaged; however, accidents do occur. Therefore, the first thing you must do upon receipt of your package is to inspect it for damage. If the box is damaged there is a possibility that the equipment inside the box may be damaged as well. If this is the case **YOU MUST FILE A CLAIM** with the delivering **CARRIER**. All shipments are **F.O.B.** our factory and it is **YOUR RESPONSIBILITY** to file a claim for damages.

**STORAGE:**

If the actuators are scheduled for installation at a later date:

1. Store off the floor.
2. Store in a climate controlled building.
3. Store in a clean and dry area.

**FOR FUTURE REFERENCE RECORD:**

1. Actuator model number \_\_\_\_\_
2. Actuator enclosure type NEMA 4 \_\_, NEMA 4X \_\_, NEMA 7 \_\_, NEMA 4 & 7 \_
3. Actuator output torque \_\_\_\_\_ LB-IN
4. Motor characteristics, Voltage \_\_\_\_\_ Hertz \_\_\_\_\_ Phase \_\_\_\_\_
5. Actuator serial number \_\_\_\_\_
6. Date of installation \_\_\_\_\_ Put into operation \_\_\_\_\_
7. Valve Data:
  - 7a. Manufacturer \_\_\_\_\_
  - 7b. Style & fig. No. \_\_\_\_\_
  - 7c. Size \_\_\_\_\_
  - 7d. End connection \_\_\_\_\_
  - 7e. Material of construction, Body \_\_\_\_\_ Stem & ball \_\_\_\_\_
  - 7f. Brake away torque \_\_\_\_\_ LB-IN @ \_\_\_\_\_ PSI
  - 7g. Other helpful data \_\_\_\_\_

**MEDIA:**

1. System media \_\_\_\_\_
2. Temperature, \_\_\_\_\_ (deg. F.) Maximum, \_\_\_\_\_ Minimum, \_\_\_\_\_.
3. Pressure \_\_\_\_\_ PSI

\*As this information is listed it is important to pay attention to all of the actuator specifications relative to the valve specifications and system requirements. If the actuator is not properly sized for the valve and application the life will be shortened or it may not work at all.



**TOOLS REQUIRED:**

**\*ADDITIONAL TOOLS WILL BE REQUIRED FOR THE SCREWS TO MOUNT THE VALVE TO THE ACTUATOR.**

**R SERIES**

Cover Screws	9/64" Allen Wrench.
Terminal Strip Screws	1/8" Wide Flat Head Screwdriver.
Cam Set Screw	5/64" Allen Wrench.
Mounting Pad Screws	3/8" Socket.

**S SERIES**

Cover Screws	SD, Phillips Head Screwdriver, Deep Base, 9/64 Allen Wrench, <b>NEMA 7</b> Enclosure, 7/16" Socket.
Position Indicator	5/64" Allen Wrench.
Terminal Strip Screws	1/8" Wide Flat Head Screwdriver.
Cam Set Screw	5/64" Allen Wrench.
Mounting Pad Screws	3/8" Socket.

**M SERIES**

Cover Screws	5/32" Allen Wrench, <b>NEMA 7</b> Enclosure, 7/16" Socket.
Terminal Strip Screws	3/16" Wide Flat Head Screwdriver.
Cam Set Screw	5/64" Allen Wrench.
Mounting Pad Screws	1/2" Socket.

**L SERIES**

Cover Screws	7/16" Socket.
Terminal Strip Screws	3/16" Wide Flat Head Screwdriver.
Cam Set Screw	5/64" Allen Wrench.
Mounting Pad Screws	9/16" Socket.

**K SERIES**

Cover Screws	1/2" Socket.
Position Indicator	5/64" Allen Wrench.
Terminal Strip Screws	3/16" Wide Flat Head Screw Driver.
Cam Set Screw	5/64" Allen Wrench.
Mounting Pad Screws	3/4" Socket.



## SUGGESTED MAXIMUM TORQUE VALUES FOR FASTENERS (IN-LBS.)

SCREW SIZE	LOW CARBON STEEL	18-8 SS	316 SS	ALUMINUM
2-56	2.2	2.5	2.6	1.4
4-40	4.7	5.2	5.5	2.9
6-32	9	10	10	5
8-32	18	20	21	10
10-24	21	23	24	13
10.32	30	32	33	19
¼-20	65	75	79	45
5/16-18	129	132	138	80
3/8-16	212	236	247	143
½-13	465	517	542	313
5/8-11	1000	1110	1160	715

### INSTALLATION:

The actuator is shipped in the open position from the factory. It is important to make sure the valve and actuator are in the same position before mounting the actuator on the valve!

1. Manually open valve.
  2. Remove valve mechanical stops.
- CAUTION:** DO NOT REMOVE ANY PARTS NECESSARY FOR THE PROPER OPERATION OF THE VALVE, I.E., PACKING GLAND, GLAND NUT, ETC.
3. Check again that the valve and actuator are in the same position.
  4. Install mounting hardware on valve, do not tighten bolts securely at this time, mount actuator to valve, and once actuator screws have been started securely tighten all nuts and bolts.

**NOTE:** ACTUATOR CONDUIT ENTRY IS NORMALLY POSITIONED PERPENDICULAR TO PIPE LINE.

5. Remove actuator cover.
6. Wire actuator using the wiring diagram inside of the actuator. If there is no wiring diagram call the factory to obtain the proper wiring diagram before attempting to wire the actuator. Equipment failure due to improper wiring is not covered under the factory warranty.

**CAUTION:** BE SURE POWER IS OFF AT THE MAIN POWER BOX.

7. Turn on power to actuator.
- CAUTION:** USE EXTREME CAUTION, AS THERE ARE LIVE CIRCUITS THAT COULD CAUSE ELECTRICAL SHOCK OR DEATH.
8. Operate the valve to the close position, check the alignment & adjust cams if necessary.
  9. Operate the valve to the open position, check the alignment & adjust cams if necessary.
  10. Check to ensure that the cover gasket is properly set in its groove. If the gasket is out of the groove, manipulate it back into place with your fingers to ensure a proper seal to eliminate the ingress of water, dust, or other debris.
  11. Replace cover and secure cover screws.



## VALVE POSITIONER DESCRIPTION:

ICI's valve positioner is used for proportional control of our complete line of electric actuators. An external command signal of 0-10V, 1-5V, or 4-20mA can be used to precisely position the actuator. Constant AC power is required to run the motor. With a loss of command signal in the 1-5V or the 4-20mA input range, the board offers three useful "loss of signal" positioning options: fail in place, fail to the open position, or fail to the closed position. All input and output options are field configurable with on board jumpers. The only other adjustments consist of Deadband and non-interactive Zero and Span trim potentiometers, which allows for easy field calibration. These controllers are available in versions for 115VAC, 230VAC, and 24VAC power and give the user isolation between the input control signal and the AC power. The unit includes a red LED indicator (indicates travel toward open position), a green LED indicator (indicates travel towards closed position), an on-board fuse, and two removable screw terminal strips (for easy servicing). Note: the mounting bracket is required for heat sinking the positioner board.

## ADDITIONAL FEATURES:

- Multiple units are easily connected in parallel to a common command signal.
- Built-in utility power supply for powering a command pot, feedback or output transmitter, and the position potentiometer.
- No external motor resistors are required.

## NOTE:

The actuator is calibrated at the factory for 90° OPEN & CLOSE using the user specified input signal. Therefore, the position potentiometer is specially set for the unit based on this travel. If this potentiometer is moved either by loosening the set screw or **manually overriding the actuator**, recalibration is **required!**

The actuator is shipped in the OPEN position, so try to avoid manually overriding the actuator when assembling to the valve. If this occurs, follow the recalibration step in this manual.



**CUSTOMER ELECTRICAL CONNECTIONS:**

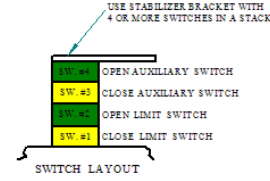
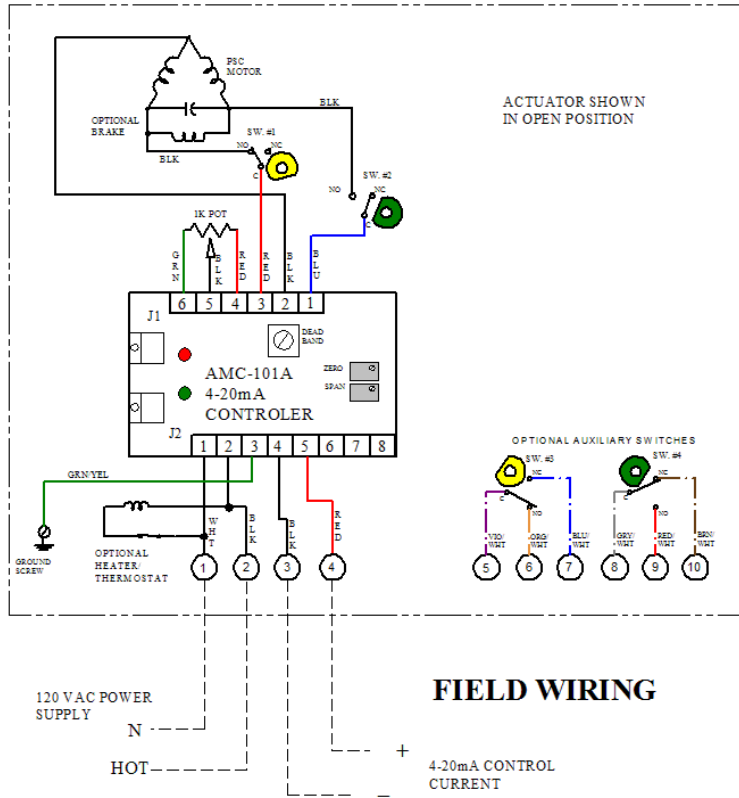

NOTE:  
 THE FEEDBACK POTENTIOMETER AND LIMIT SWITCHES HAVE BEEN SET AT THE FACTORY - THEY DO NOT REQUIRE FURTHER CALIBRATION.  
 (S SERIES; J1-4 IS GREEN, J1-6 IS RED WIRE)

TO CALIBRATE THE OPEN AND CLOSE POSITION USE THE TRIM POTS LABELED Z (ZERO) FOR CLOSE AND S (SPAN) FOR OPEN.

STEP ONE SHOULD BE TO ADJUST THE ZERO POSITION AND STEP TWO IS TO ADJUST THE SPAN POSITION.

**W010612**

**115VAC MODULATING ACTUATOR WITH 2 AUXILIARY SWITCHES, MOTOR BRAKE & HEATER AND THERMOSTAT (OPTIONAL) WIRING DIAGRAM**

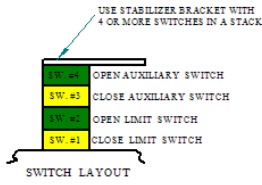
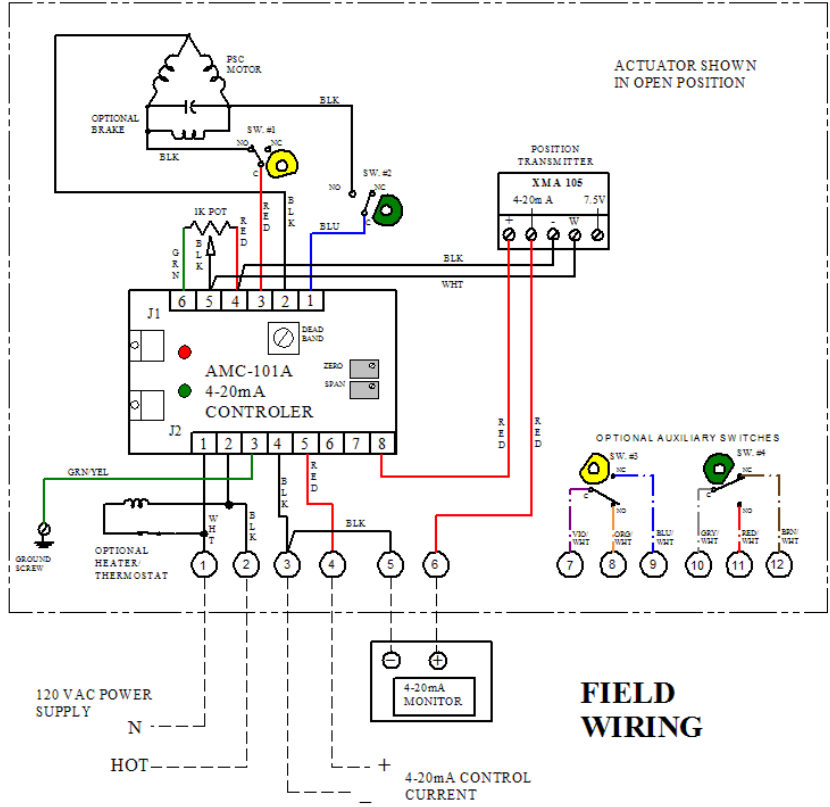

NOTE:  
THE FEEDBACK POTENTIOMETER AND LIMIT SWITCHES HAVE BEEN SET AT THE FACTORY - THEY DO NOT REQUIRE FURTHER CALIBRATION. (S SERIES; J1-4 IS GREEN, J1-6 IS RED WIRE)

TO CALIBRATE THE OPEN AND CLOSE POSITION USE THE TRIM POTS LABELED Z (ZERO) FOR CLOSE AND S (SPAN) FOR OPEN.

STEP ONE SHOULD BE TO ADJUST THE ZERO POSITION AND STEP TWO IS TO ADJUST THE SPAN POSITION.

**FIELD WIRING**

**W140904**

**115VAC MODULATING ACTUATOR WITH POSITION FEEDBACK, 2 AUXILIARY SWITCHES, MOTOR BRAKE & HEATER AND THERMOSTAT (OPTIONAL) WIRING DIAGRAM**

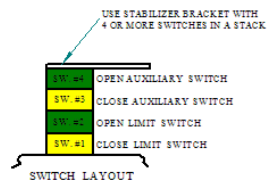
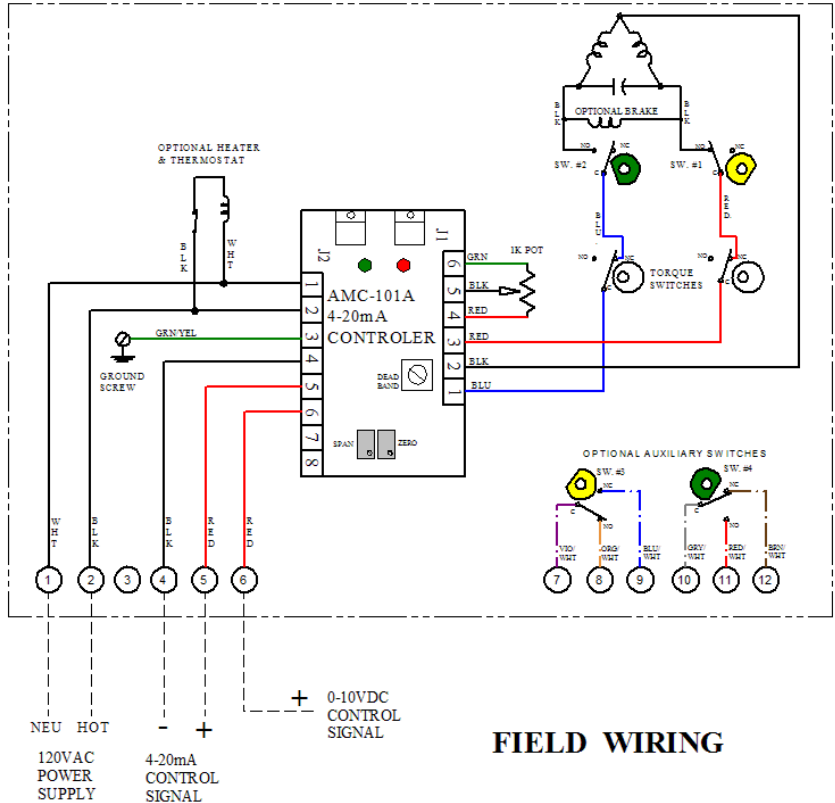

NOTES:  
 ACTUATOR SHIPPED IN OPEN POSITION.  
 20mA REPRESENTS OPEN POSITION.  
 DO NOT ADJUST FEEDBACK POTENTIOMETER OR LIMIT SWITCHES THEY ARE FACTORY SET AND DO NOT REQUIRE CALIBRATION.  
 TO CALIBRATE THE OPEN AND CLOSE POSITION USE THE ZERO (4mA) AND SPAN (20mA) TRIM POTENTIOMETERS, FOR DETAILS SEE THE MANUAL. THE TORQUE SWITCH MAY REQUIRE ADDITIONAL CALIBRATION.

FIELD WIRING

W101110

**115VAC MODULATING K SERIES ACTUATOR WITH 2 AUXILIARY SWITCHES, MOTOR BRAKE & HEATER AND THERMOSTAT (OPTIONAL) WIRING DIAGRAM**





## POWER / SIGNAL (J2):

Power is connected to input terminals as shown in the wiring diagrams above. The fuse installed on the unit is rated for maximum output current that can be safely delivered by the AC to the motor. Replacement fuses must not exceed these maximum ratings (5A slow blow) to prevent damage to the unit.

An appropriate command signal, either 0-10V, 1-5V, or 4-20mA, should be connected to the input terminals (as shown in the wiring diagram). The positioner must be configured for the type of command signal that is to be used - jumper plug JP1 must be installed whenever a 4-20mA or 0-10V input is used. Terminal 7 of J2 provides an auxiliary +10V output, which can be used to connect a command potentiometer. By connecting one end of a potentiometer to terminal 7, the other end to terminal 4, and the wiper to terminal 6, a local control knob can be implemented. Terminal 8 provides an auxiliary +24VDC output, which can be used to power feedback transmitter.

**WARNING!** Verify that the unit is properly grounded for safety.

## ACTUATOR (J1):

The position potentiometer is connected so that when the actuator moves towards the open position (CCW), the potentiometer's resistance between terminals 4 and 5 on J1 will increase. This can also be measured as a voltage - the voltage between terminals 4 and 5 on J1 should increase when the actuator moves towards the open position (CCW). If the potentiometer is wired incorrectly, the typical response of the unit will be to run the actuator to the full open or closed position (the appropriate open/close indicator will remain on) regardless of the command signal input. For best results, position the actuator to the midway point between the open and closed positions; then adjust the position potentiometer for approximately 5VDC (or 1/2 of the potentiometer's resistance) between terminals 4 and 5 of J1. Since the position potentiometer is crucial for proper operation of the modulating board, the following items should be carefully observed:

- 1 - Potentiometer resistance should be a value from 1K to 10K ohms.
- 2 - The potentiometer should be a linear taper type.
- 3 - The potentiometer must be properly wired to provide the correct position signal.
- 4 - The potentiometer must be properly and securely mounted in order to provide a reliable signal to the board.

## OUTPUT INDICATORS:

ICI's modulating units have on-board indicators that identify when one of the motor outputs is turned on. When the open output is turned on, the red LED indicator will turn on, and when the close output is turned on the green LED indicator will turn on. Many actuators are equipped with limit switches at the open and closed positions which are intended to disconnect power to the motor to prevent mechanical damage. For this reason, it is possible that the positioner will indicate that one of the motor outputs is turned on when the actuator is not in motion. However, it should be noted that when the indicator is on,



power is applied to the motor output. If one of the motor output LEDs is on and the motor is not turning, see the **CALIBRATION** section below.

### **LOSS OF INPUT SIGNAL:**

When the 1-5V or 4-20mA type command signal is used, the modulating board can detect if the input signal has been disconnected. The unit can be configured to respond to the loss of command signal in one of three ways: turn both outputs off (leaving the actuator in its last position at the time signal was lost), turn on the open output (to move the actuator to the full open position), or turn on the close output (to move the actuator to the full closed position). AC power must be present for the actuator to fail open or fail closed. To select the desired response to a loss of input signal, move jumper plug JP2 (last position), JP3 (fail open), or JP4 (fail close) as shown in the board diagram. **CAUTION! Power must be disconnected when installing or removing these jumpers - damage to the unit may occur if these jumpers are set with power on.**

When using this feature, certain precautions should be observed. For applications using the 0-10V input signal, the unit cannot detect a loss of signal; do not install jumper plugs JP2, JP3, and JP4 for these applications. When JP3 or JP4 are installed, the unit will turn on one of the motor outputs when the input signal is lost; if the actuator does not use limit switches, these selections should not be used.

### **CALIBRATION:**

The non-interactive zero and span adjustments of the modulating board allow for easy calibration once the unit is installed. Follow these steps to calibrate the unit (see board diagram for the location of the adjustments):

- 1 - Apply AC power to the actuator, and set the command input signal to minimum: 0V for 0-10V input type 1V for 1-5V input type 4mA for 4-20mA input type.
- 2 - Adjust the "Zero" adjustment so that the actuator moves to the desired closed position. If the desired position cannot be achieved, check that the position potentiometer provides a feedback signal as described under "ACTUATOR (J1)"; also, check the position of the CLOSE limit switch. Adjust the CLOSE cam CCW to allow for more travel in CLOSE position, if needed.
- 3 - If the actuator is hunting for position, turn the "Deadband" adjustment clockwise until hunting stops. If the actuator is not hunting for position, turn the "Deadband" adjustment counterclockwise until the actuator begins to hunt; then turn the "Deadband" adjustment slightly clockwise until hunting stops. **WARNING!** Actuator failure may occur if the "Deadband" adjustment is set to allow continuous hunting. This can cause excessive wear of motor bearings, gear train, dynamic brake, and position potentiometer. Hunting can also cause the internal temperature of the actuator housing to rise to a level that exceeds the maximum rating of the motor.
- 4 - Set the command signal input to maximum: 10V for 0-10V input type 5V for 1-5V input type 20mA for 4-20mA type.



5 - Adjust the "Span" adjustment so that the actuator moves to the desired open position. If the desired position cannot be achieved, check the position of the OPEN limit switch. Adjust the OPEN cam CW to allow for more travel in OPEN position, if needed.

**NOTE:** The "Zero" adjustment is an offset setting rather than an absolute setting. Should the "Zero" adjustment be changed, the "Span" adjustment should be checked for the desired open position. Setting of the "Span" adjustment has no effect on the "Zero" adjustment.

6 - To check proper operation and linearity, set the command signal to halfway: 5V for 0-10V input type 3V for 1-5V input type 12mA for 4-20mA input type. Verify that the actuator's position is midway between the open and closed positions.

### **REVERSE ACTING CALIBRATION (4mA = open & 20mA =closed):**

When converting a direct acting actuator to a reverse acting actuator, two changes in wiring must be made and the cams reset:

- 1 - Reverse the feedback potentiometer wires connected to J1-4 and J1-6.
- 2 - Reverse the motor output wires connected to J1-1 and J1-3.

**NOTE: DO NOT** reverse the input signal polarity. Also, make sure that both wiring changes are made - if only one is made, the actuator will run to either full open or full closed. After the wiring changes have been made, refer to **CALIBRATION** for setting the zero and span adjustments.

### **RECALIBRATION OF MODULATING BOARD**

- 1) Move motor and valve to 45° or mid-position between open and close.
- 2) Loosen set screw on the potentiometer shaft gear.
- 3) Turn power to the actuator OFF so that the motor does not move.
- 4) Pull the 6-terminal J1 green connector out away from the controller board so that the potentiometer is isolated from the circuit card.
- 5) Using a DVM, measure the resistance of the potentiometer between terminals 4 & 5 at the free hanging J1 connector.
- 6) Rotate the potentiometer shaft gear until the resistance reads approximately 500 ohms (+/-10).
- 7) Tighten down the potentiometer shaft gear set screw to lock the gear in place.
- 8) Push the green J1 connector back into the controller board.
- 9) Connect a User Control Signal (4-20mA, 0-10v, etc.) to the actuator input terminals. This may be either to a white input terminal strip or directly to the 8 –terminal J2 Connector. The connections at J2 (8 Terminal Green Connector) are: terminal 4 = (-); terminal 5 = (4-20mA +); terminal 6 = (0-10v +). Consult your actuator's wiring diagram for the proper terminal connections.
- 10) Set the User Control Signal to the CLOSE level (0%) - 4.0mA or 0V.
- 11) Make sure the Deadband pot on the controller board is at mid position.
- 12) Loosen the set screws to the 2 Lower CAMs and rotate the CAMs so that the flat of each CAM is toward the switch levers. The switch levers should NOT be pressed in.
- 13) Turn the AC power back ON to the actuator. Use **CAUTION** with the next few steps because power is present and an electrical shock is possible.



- 14) The Green LED on the board should come on. If not, adjust the Zero Pot until the Green LED illuminates.
- 15) Press the bottom switch lever (or CLOSE CAM) in so that the motor starts to move to the CLOSE position.
- 16) When the valve reaches the fully CLOSED position, release the switch lever to stop the motor. If the valve does not reach the fully CLOSED position on the first adjustment, keep adjusting the Zero Pot until full travel is reached.
- 17) Adjust the Zero Pot so that both the Green and Red LEDs are OFF.
- 18) Adjust the CLOSE (bottom) CAM so that the bottom switch lever is pressed in, but further travel in the CLOSE direction would “click” the lever to the open position. Tighten the bottom CAM set screw.
- 19) Set the User Control Signal to the OEPN level (100%) - 20.0mA or 10V.
- 20) The Red LED should turn on.
- 21) Press the top switch lever (or OPEN CAM) in so that the motor starts to move to the OPEN position.
- 22) When the valve reaches the fully OPEN position, release the switch lever to stop the motor. If the valve does not reach the fully OPEN position on the first adjustment, keep adjusting the Span Pot until full travel is reached.
- 23) Adjust the Span Pot so that both the Green and Red LEDs are OFF.
- 24) Adjust the OPEN (top) CAM so that the top switch lever is pressed in, but further travel in the OPEN direction would “click” the lever to the open position. Tighten the top CAM set screw.
- 25) Deliver OPEN, MID and CLOSE (0%, 50% & 100%) Control Signals a few times to verify that the valve travels to the proper positions. Adjust as described above, if further adjustments are needed.
- 26) Turn OFF the AC Power and check that all of the set screws are tightened. Replace the actuator cover and tighten the screws.
- 27) Re-apply the AC power to the actuator.



**MODULATING BOARD DIMENSIONS:**

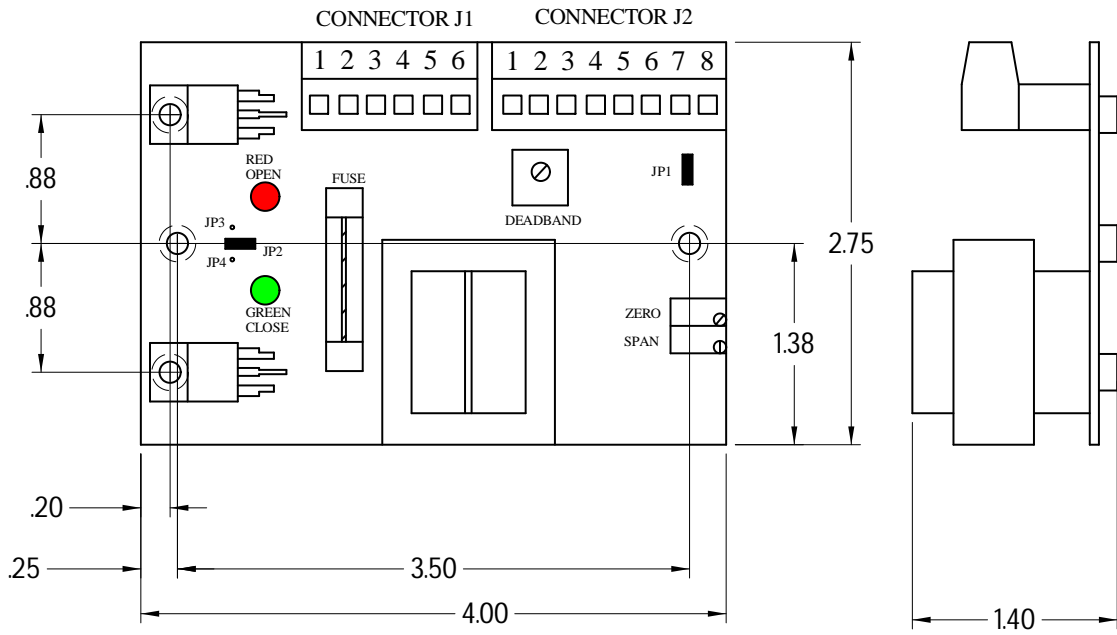

22018	115Vac
22018A	24Vac
22018C	230Vac



## SPECIFICATIONS

### POWER REQUIREMENTS:

117VAC  $\pm$ 10%, 50/60 Hz  
234VAC  $\pm$ 10%, 50/60 Hz  
24VAC  $\pm$ 10%, 50/60 Hz  
3.6 VA typical (not including output load)  
**Fuse Type:** 5A 3AG Slo-Blo

### COMMAND SIGNAL INPUT:

#### 0-10 VDC Input

Input Impedance: 11K ohms minimum  
External Command Potentiometer: 1K ohm

#### 1-5 VDC Input

Input Impedance: 1M ohms minimum  
Loss of Command Signal Threshold:  $\square$ 0.75V

#### 4-20 mA Input

Input Impedance: 250 ohms  $\pm$ 1%  
Loss of Command Signal Threshold:  $\square$ 3mA

### FEEDBACK SIGNAL INPUT:

Input Voltage: 0 to 10 VDC  
External Feedback Potentiometer: 1K ohm to 10K ohms

### POWER SUPPLY OUTPUTS:

Input or Output Transmitter Power: (J2-8): 24VDC @ 20mA max  
Command Signal Potentiometer Power: (J2-7): 10VDC @ 10mA max  
**NOTE:** Do not connect these outputs to other power supplies.

### AC MOTOR OUTPUTS:

Off-state Leakage Current: <15mA  
Maximum Load Current @ 60° C:  
AMC-101x: 5A (when properly mounted to bracket)

### CONTROL ADJUSTMENTS:

Zero: adjustable throughout feedback signal range  
Span: adjustable throughout command signal range  
Deadband: adjustable from 0.12% to 2.4% of span  
Hysteresis: 1%  
Linearity: 1%  
Repeatability: 2%

### ENVIRONMENTAL:

Operating Temperature Range: 0 °C to 60 °C  
Storage Temperature Range: -40 °C to 85 °C  
Relative Humidity Range: 0 to 90% (non-condensing)



## MAINTENANCE:

After your ICI electric actuator has been properly installed there is little or no maintenance ever required. The gear train has been permanently lubricated at the factory and requires no routine maintenance. In the event it becomes necessary to perform maintenance on the actuator upon reassembling, we recommend using Lubriplate EMB grease.

## SET AUXILIARY SWITCHES:

### TOOLS REQUIRED:

- |                   |   |                           |
|-------------------|---|---------------------------|
| 1. COVER REMOVAL  | - | PHILLIPS HEAD SCREWDRIVER |
| 2. CAM ADJUSTMENT | - | 5/64" ALLEN WRENCH        |

### NOTE:

*Read these instructions completely before beginning installation, if you have any questions please call our service technician at 1-800-662-9424 for assistance.*

1. Turn off power supply to actuator.
  2. Remove screws securing cover to gearbox, remove cover.
  3. Turn on power to actuator.
- CAUTION: At this time there are live circuits in the actuator; contact may cause electrical shock or death.**
4. Operate actuator to the close position.
  5. Rotate the third cam up from the base CCW so the setscrew is accessible and the round of the cam has switch arm compressed.
  6. Rotate the cam CW until the switch snap from the NO to the NC contact & switch arm moves away from switch body.
  7. Lock cam in position by securing 8-32 x 1/4" long set screw to shaft.
  8. Operate actuator to the open position.
  9. Rotate top cam CW so set screw is accessible and round of cam has switch arm compressed.
  10. Rotate top cam CCW until the switch snaps from the NO to the NC contact & switch arm moves away from switch body.
  11. Lock cam in position by securing 8-32 x 1/4" long set screw to shaft.
  12. Test setting to assure proper operation using Digital Volt Meter for proper switch closure.
  13. If desired setting has not been achieved repeat steps 2 through 11.
  14. Once proper settings have been accomplished replace cover and secure cover screws.

## CHECK POWER OFF BRAKE:

### TOOLS REQUIRED:

1. 5/32" ALLEN WRENCH
2. 3/16" WIDE FLAT SCREWDRIVER
3. 0.050 ALLEN WRENCH
4. PHILLIPS HEAD SCREWDRIVER (COVER REMOVAL: SD SERIES).

1. Turn off supply power to actuator.
2. Remove screws securing cover to gearbox, remove cover.
3. Using .050 Allen wrench loosen setscrew in brake armature hub to motor shaft.
4. Pull up center hub to remove from brake & motor shaft.

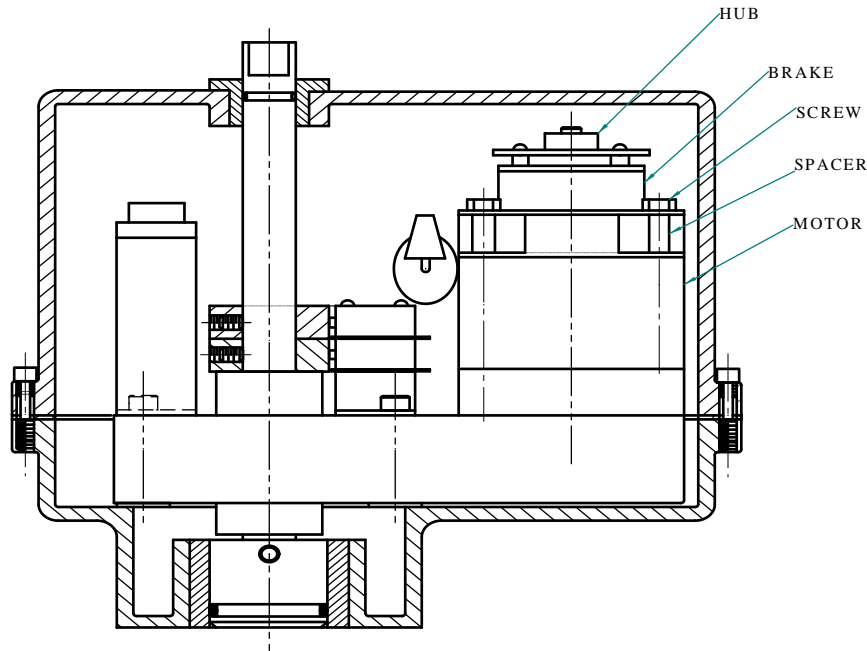

FIG. 1

5. Apply power to terminals #1 and #2, actuator should rotate to the open position.
6. Apply power to terminals #1 and #3, actuator should rotate to the close position.
7. If actuator runs, brake is bad and should be replaced.

### **DUTY CYCLE:**

ICI actuators rated 100 LB-IN up to 1500 LB-IN output torque are rated for 25% duty cycle at 100% ambient temperature at rated torque (75% duty cycle motors are available upon request). Actuators rated for 2000 LB-IN output torque and greater are rated for continuous duty.

### **THERMAL OVER LOAD:**

All alternating current (AC) motors are equipped with thermal over load protection to guard the motor against damage from overheating.

### **MECHANICAL OVER LOAD:**

ICI' actuators are all designed to withstand stall conditions. It is not recommended to subject the unit to repeated stall conditions; however, should it occur the actuator would not experience gear damage.





## ORDERING PARTS:

When ordering parts please specify:

- Actuator Model Number
- Actuator Serial Number
- Part Number
- Part Description

## RECOMMENDED SPARE PARTS:

Set of cams, switches, feedback potentiometer and an AC modulating board.

## NEMA 7 ENCLOSURE, GENERAL:

In general, operation and maintenance of a NEMA 7 electric actuator is no different than that of a NEMA 4 electric actuator. However, there are some precautions that must be followed.

1. **DO NOT** install in ambient temperatures that exceed **140 degrees F**.
2. **DO NOT** under any circumstances **remove the actuator cover** while in a hazardous location when the contacts are still live, this could cause ignition of hazardous atmospheres.
3. **DO NOT** under any circumstances **use a NEMA 7 electric actuator in a hazardous location that does not meet the specifications for which the actuator was designed**. The actuator is clearly tagged with the NEMA classification it was designed for.
4. Mount, test and calibrate actuator on valve in non-hazardous location.
5. When removing the cover care must be taken not to scratch, scar or deform the flame path of the cover or base of the actuator, this will negate the NEMA 7 rating of the enclosure.
6. When replacing the cover on actuators rated NEMA 4 and 7 take care that the gasket is in place to assure the proper clearance after the cover is secured. After securing the cover screws check the clearance between the cover and the base, a .002" thick by 1/2" wide feeler gauge may not enter between the two mating faces more than .125".
7. All electrical connections must be to state and local codes and in accordance with the specifications for which the unit is being used.

*\*After proper installation the actuator will require little or no maintenance. In the event maintenance is required remove it from the hazardous location before attempting to work on it. If the actuator is in a critical application and down time is not permitted it is advisable to have a spare actuator in stock.*



**INDELAC CONTROLS INC.**   
**AMERICAN MADE ACTUATORS & CONTROLS**



**INDELAC 1-YEAR STANDARD WARRANTY POLICY:**

INDELAC CONTROLS, INC. (ICI) WARRANTS THAT FOR A PERIOD OF **1 YEAR** FROM THE DATE OF SHIPMENT IT WILL EITHER REPAIR OR REPLACE, AT ITS OPTION, ANY OF ITS PRODUCTS, WHICH PROVE TO BE DEFECTIVE IN MATERIAL OR WORKMANSHIP.

THIS WARRANTY DOES NOT COVER DAMAGE RESULTING FROM CAUSES SUCH AS ABUSE, MISUSE, MODIFICATION OR TAMPERING.

THIS WARRANTY IS EXTENDED ONLY TO THE REGISTERED PARTY, FOR WHICH THE PRODUCT SERIAL NUMBER MATCHES. THE EXTENDED WARRANTY OF ICI'S PRODUCT AND IS NOT TRANSFERABLE.

TO OBTAIN SERVICE UNDER THIS WARRANTY, THE PURCHASER MUST FIRST OBTAIN A RETURN AUTHORIZATION NUMBER FROM ICI. PRODUCTS MUST BE RETURNED TO ICI FREIGHT PREPAID FOR EVALUATION.

IF THE UNIT FAILED DUE TO POOR WORKMANSHIP OR MATERIALS THE UNIT WILL BE REPAIRED OR REPLACED. THE UNIT WILL BE RETURNED GROUND/STANDARD FREIGHT PAID BY ICI, IF AIR/RUSH SHIPMENT IS REQUESTED THE PURCHASER SHALL PAY THE DIFFERENCE.

THIS WARRANTY IS IN LIEU OF ALL OTHER OBLIGATIONS, LIABILITIES OR EXPRESSED WARRANTIES. ANY IMPLIED WARRANTIES, INCLUDING ANY IMPLIED WARRANTY OF MERCHANTABILITY ARE HEREBY EXPRESSLY EXCLUDED.

IN NO EVENT SHALL ICI BE LIABLE FOR SPECIAL, INCIDENTAL OR CONSEQUENTIAL DAMAGES ARISING IN CONNECTION WITH THE USE OF ITS PRODUCTS, OR FOR ANY DELAY IN THE PERFORMANCE OF THIS WARRANTY DUE TO CAUSES BEYOND ITS CONTROL.

6810 POWERLINE DR. - FLORENCE, KY. 41042 - TELEPHONE 859-727-7890, TOLL FREE 1-800-662-9424  
FAX. 859-727-4070, E-MAIL: [DVOGES@INDELAC.COM](mailto:DVOGES@INDELAC.COM), OR [MROBINSON@INDELAC.COM](mailto:MROBINSON@INDELAC.COM)  
VISIT OUR WEBSITE AT [WWW.INDELAC.COM](http://WWW.INDELAC.COM)

**REGISTER ONLINE FOR INDELAC'S EXTENDED 2-YEAR WARRANTY**



Frequently Asked Questions

SYMPTOM	PROBLEM	SOLUTION
<p><b>ACTUATOR DOES NOT RESPOND TO CONTROL SIGNAL.</b></p>	<p>Power not on Actuator wired wrong Wrong voltage</p> <p>Thermal overload activated</p> <p>Actuator and valve in opposite positions when actuator was mounted.</p> <p>Input Command Signal not Present</p> <p>Position Potentiometer Problem</p> <p>Bad Brake</p>	<p>Turn on power Check wiring diagram &amp; rewire Check power supply &amp; make appropriate changes Allow motor to cool, actuator will automatically reset Remove actuator and rotate 90 degrees &amp; remount</p> <p>Check wiring for connection &amp; Proper polarity Check pot wiring &amp; resistance</p> <p>Remove brake hub &amp; try to run</p>
<p><b>ACTUATOR WILL NOT OPEN OR CLOSE COMPLETELY.</b></p>	<p>Travel limits set wrong Valve torque too high for actuator Mechanical stops not removed</p> <p>Positioner Board not set properly</p> <p>Position Potentiometer Problem</p>	<p>Reset cams. Install correct size actuator. Remove stops, CAUTION: Do not remove any part required for proper operation</p> <p>Recalibrate Zero &amp; Span pots</p> <p>Check pot wiring &amp; resistance</p>
<p><b>VALVE OSCILLATES.</b></p>	<p>Valve torque too high for actuator Actuator without brake installed on butterfly valve Motor brake out of adjustment. Set screw loose in brake disc</p>	<p>Install correct size actuator.</p> <p>Install brake Adjust brake Adjust brake and tighten set-screw</p>
<p><b>MOTOR RUNS BUT OUTPUT SHAFT DOES NOT ROTATE.</b></p>	<p>Gear damage or sheared pin</p>	<p>Contact ICI or nearest distributor</p>

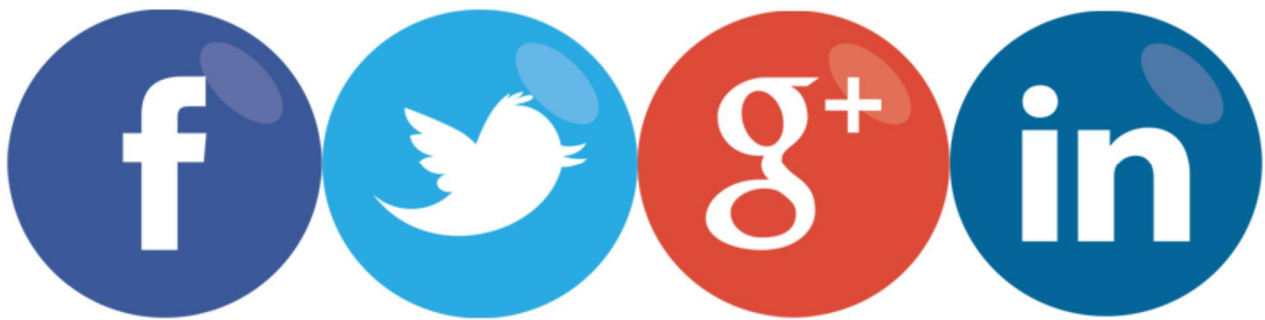

## Contact Information

Debbie Voges	<a href="mailto:dvoges@indelac.com">dvoges@indelac.com</a>	859-727-7890 ext. 100
Matt Robinson	<a href="mailto:mrobinson@indelac.com">mrobinson@indelac.com</a>	859-727-7890 ext. 109
Talbot Caywood	<a href="mailto:tcaywood@indelac.com">tcaywood@indelac.com</a>	859-727-7890 ext. 110

For News & Updates, Check Out Our Blog: [www.blog.indelac.com](http://www.blog.indelac.com)