

FlowTek®

INSTALLATION - MAINTENANCE MANUAL

Series 19-CL 150, 300, 600

Segmented Ball valve

Size 1" (DN25) thru 12" (DN300)



Table of Contents

Class 150-300

1. DESIGN3
 2. GENERAL INFORMATION3
 2.1 Use3
 2.2 Operations3
 2.3 Applicability3
 2.4 Terms related to safety3
 2.5 Protective clothing4
 2.6 Qualified personnel4
 2.7 Spare Parts4
 2.8 Service / Repair4
 2.9 Storage4
 3. UNPACKING4
 4. INSTALLATION5
 5. QUICK-CHECK5
 6. PREVENTATIVE MAINTENANCE6
 7. REMOVING VALVE FROM LINE7
 8. ACTUATOR7

Appendix - A (Class 150/300)

9. DISASSEMBLY AND REASSEMBLY8
 9.1 Removing Actuator from Body8
 9.2 Replacing the Seat8
 9.2.1 Detaching the Seat8
 9.2.2 Installing the Seat8
 9.3 Dismantling the Valve9
 9.4 Inspection of Removed Parts9
 9.5 Assembly9
 9.6 Remounting the Actuator11
 10. PARTS DIAGRAM12

Appendix - B (Class 600)

11. DISASSEMBLY AND REASSEMBLY14
 11.1 Removing Actuator from Body14
 11.2 Dismantling the Valve14
 11.3 Reassembling the Valve16
 11.4 Remounting the Actuator17
 12. PARTS DIAGRAM18

**INSTALLATION – MAINTENANCE MANUAL
Series 19 – Segmented Ball valve
Size 1” (DN25) thru 12” (DN300)**

1. DESIGN:

The design features of this valve include a one piece construction body which results in simplified maintenance and trouble free operation.

The valve features a characterized ball segment for high rangeability with Splined stem connection for precise control, maintenance friendly Segment-Stem assembly, Low friction Stem and thrust bearing for longer life, Integral actuator mounting pads, and interchangeable seats.

The valve is either soft or metal seated. Tightness derives from the spring force pressing the seat against segment. The structure of the valve supplied may vary, depending on the customer’s requirements.

2. GENERAL INFORMATION

2.1 - USE

The following instructions are designed to assist in the unpacking, installation, and maintenance as required for Flow-Tek products. Product users and maintenance personnel should thoroughly review this manual prior to installing, operating, or performing any maintenance.

In most cases, Flow-Tek valves, actuators and accessories are designed for specific applications (e.g. with regard to medium, pressure and temperature). For this reason, they should not be used in other applications without first contacting the manufacturer.

WARNING: Before installing the equipment, confirm that it is suitable for the intended service. The identification tags describe the maximum allowable service conditions for this product. Be sure that the installation is protected by appropriate pressure control and safety devices to insure that acceptable limits are not exceeded.

2.2 - OPERATION

Operation of the valve is done by turning the stem a 1/4 turn (90 degrees turn). Clockwise to close, counter clockwise to open.

2.2A Valve open position

The double “D” parallel to pipeline (figure 1)

2.2B Valve closed position

The double “D” perpendicular to pipeline (figure 1)

CAUTION: Valves with actuators should be checked for actuator - valve alignment. Misalignment will result in high operational torque and damage to valve stem and seals.

2.3 - APPLICABILITY

The following instructions are applicable to the maintenance and installation of Flow-Tek Segmented ball valves. These instructions cannot claim to cover all details of all possible product variations, nor can they provide information for every possible example of installation, operation or maintenance. This means that the instructions normally include only the directions to be followed by qualified personal using the product for its defined purpose. If there are any uncertainties in this respect, particularly in the event of missing product related information, clarification must be obtained via the appropriate Flow-Tek sales office.

2.4 - Terms related to safety

The terms **DANGER**, **WARNING**, **CAUTION**, and **NOTE** are used in this document to highlight particular dangers and/or to provide additional information on points which may not be clearly obvious.

DANGER: Indicates that death, severe personal injury and/or substantial property damage will occur if proper precautions are not taken.

WARNING: Indicates that danger of death or severe personal injury and/or property damage can occur if proper precautions are not taken.

CAUTION: Indicates that minor personal injury and/or serious damage to property can occur if the appropriate precautions are not taken.

NOTE: Indicates and provides additional technical information which may not be obvious, even to qualified personnel.

Compliance with other notes, which may not be particularly emphasized, with regard to transport, assembly, operation and maintenance and with regard to technical documentation (e.g. in the operating instructions, product documentation, or on the product itself) is essential, in order to avoid faults, which can directly or indirectly cause severe personal injury or property damage.

2.5 - Protective clothing

Flow-Tek products are often used in critical applications (e.g. under extremely high pressures with dangerous, toxic or corrosive mediums). When performing service, inspection, or repair operations, always ensure that the valve and the actuator are depressurized and that the valve has been cleaned, and that it is free of harmful substances. In such cases, pay particular attention to personal protection (e.g. protective clothing, gloves, glasses, etc.).

2.6 - Qualified personnel

Qualified personnel are people who on account of their education, experience, training, and knowledge of relevant standards, specifications, accident prevention, and operating conditions have been authorized by those responsible for the safety of the plant to perform the necessary work, and recognize and avoid possible dangers.

2.7 - Spare Parts

Use only Flow-Tek original spare parts. Flow-Tek cannot accept responsibility for any damages that occur from using spare parts or fastening materials from other manufacturers. If Flow-Tek products (especially sealing materials) have been on store for long periods of time, check them for corrosion or deterioration before putting them into use.

2.8 - Service / Repair

To avoid possible injury to personnel or damage to products, safety terms must be strictly adhered to. Modifying this product, substituting non-factory parts, or using maintenance procedures other than those outlined in these Installation, Operation and Maintenance Instructions could drastically affect performance, be hazardous to personnel and equipment, and may void existing warranties. Apart from the operating instructions and the obligatory accident prevention directives valid in the country of use, all recognized regulations for safety and good engineering practices must be followed.

WARNING: Before products are returned to Flow-Tek for repair or service, Flow-Tek must be provided with a certificate that confirms that the product has been decontaminated and is clean.

2.9 - Storage

Flow-Tek products are well protected from corrosion. Nevertheless, Flow-Tek products must be stored adequately in a clean, dry, environment. Plastic caps are fitted to protect the flange faces and prevent the ingress of foreign materials. These caps should not be removed until the valve is actually mounted into the system.

3. UNPACKING

While unpacking the valve, check the packing list against the materials received. Lists describing the valve and accessories are included in each shipping container.

When lifting the valve from shipping container, use straps through valve body. Take care to position lifting straps to avoid damage to the tubing and mounted accessories.

WARNING: Never lift the valve or valve package by the actuator, positioner, limit switch or their piping. When lifting a valve be aware that the center of gravity may be above the lifting point. Therefore, support must be given to prevent the valve from rotating. Failure to do so can cause serious injury to personnel and damage to the valve and nearby equipment.

Contact your shipper immediately if there is shipping damage.

Should any problem arise, call your Flow-Tek representative.

DANGER: Before installation check the order number, serial number, and/or the tag number to ensure that the valve and actuator being installed are correct for the intended application.

CAUTION: Do not insulate extensions that are provided for hot or cold services.

4. INSTALLATION

Before installing the valve, clean the pipeline of all contamination, carbon deposits, welding chips, and other foreign material. Carefully clean gasket surfaces to ensure a tight seal. Pipelines must be correctly aligned to ensure that the valve is not fitted under tension.

Fire protection must be provided by the user.

Check the direction of fluid flow to ensure that the valve is correctly installed. Flow direction is indicated by the arrow on the body.

DANGER: To avoid serious injury, keep hands, hair, clothing, etc. away from the segment and seat when the valve is working.

For valves with pneumatic actuator & accessories:

Connect the air supply and instrument signal lines. Throttling control valves are equipped with a valve positioner. Connections are marked for the air supply and the instrument signal. Check that the actuator and positioner can withstand the maximum air supply from the network. The required air supply is indicated on a sticker located on the actuator. An air regulator will be necessary in certain cases in order to limit the supply pressure. Air filter is recommended unless the air supplied is exceptionally clean and dry (air quality without humidity, oil, or dust as per IEC 770 and ISA-7.0.01). All connections must be completely tight.

CAUTION: On valves equipped with air filters, the air filter must point down to perform properly.

For Electrical actuators:

Refer to Installation & maintenance manual of supplied electric actuator.

Use the bolts indicated in **Table 1** on page 6 for installing the valve in the pipeline, and then tighten alternately according to good practice. The user must in all cases confirm the capacity of the bolts to ensure a sufficiently tight gasket seal for the expected service conditions.

Be sure to provide proper overhead clearance for the actuator to allow for disassembly of the actuator from the valve body. Refer to the appropriate general assembly drawing for proper clearances.

5. QUICK-CHECK

Before commissioning, check the control valve by following these steps.

Check for full stroke by varying the instrument signal settings appropriately. Observe the segment position indicator located on the actuator or the positioner. The segment should change position with a smooth turning movement.

Check all air connections for leaks. Tighten or replace any leaking lines.

Check packing box bolting for proper tightness.

CAUTION: Do not over tighten packing. This can cause excessive packing wear and high stem friction that may impede stem movement. After the valve has been in service for a short period, recheck the packing-box nuts. If the packing box leaks, tighten the nuts just enough to stop the leak.

Make sure the valve fails in the correct direction in case of air failure. This is done by positioning the valve at mid stroke and turning off the air supply and observing the failure direction. If the action is incorrect, see the section "Reversing the Air-action" in the instructions of the installation, operation and maintenance manual of the appropriate actuator.

6. PREVENTATIVE MAINTENANCE

- At least once every six months, check for proper operation by following the preventative maintenance steps outlined below. These steps may be performed while the valve is in line and without interrupting service. If an internal problem is suspected, refer to section "9" for class 150/300 and "11" for class 600.
 - Look for signs of gasket leakage through the end flanges and post. If necessary, re-torque end flanges and post cover.
 - Examine the valve for damage caused by corrosive fumes or process drippings.
 - Clean the valve and repaint areas of severe oxidation.
 - Check the packing-box for proper tightness. If there is a persistent leak, change the packing after referring to sections "9.3" class 150/300 and "11.2" class 600 for dismantling the valve, "9.5" class 150/300 and "11.3" class 600 for Reassembling the valve.
- CAUTION:** Do not over tighten packing. This can cause excessive packing wear and high friction that may impede stem movement.
- If the valve is equipped with a lubricator, add lubricant if necessary.
 - If possible, stroke the valve and check for smooth, full stroke operation. Unsteady stem movement may indicate an internal valve problem.
 - Check the calibration of the positioner/controller if available. For further preventative maintenance, see the instructions in the installation, operation and maintenance manual for the applicable positioner/controller.
 - Ensure all accessories, brackets and bolting are securely fastened.
 - If possible, remove power source (air supply/electrical signal) and observe actuator for correct fail-safe action.
 - Check the actuator and all air connections for leaks.
 - If an air filter is supplied, check and replace the cartridge if necessary.
- Table 1: Flange Bolting Specifications**

Size (in)	ANSI CLASS RATINGS	Bolt Length (mm) ⁽²⁾	Torque (N-m) ⁽¹⁾	
			Low Strength	Intermediate Strength
1	150	65	31	82
	300	75	63	165
	600	90 / 80 ⁽³⁾	63	165
1½	150	70	31	82
	300	90	110	295
	600	110 / 90 ⁽³⁾	110	295
2	150	85	63	165
	300	90	63	165
	600	110 / 95 ⁽³⁾	63	165
3	150	90	63	165
	300	110	110	295
	600	125 / 110 ⁽³⁾	110	295
4	150	90	63	165
	300	115	110	295
	600	145 / 125 ⁽³⁾	179	478
6	150	100	110	295
	300	120	110	295
	600	170 / 150 ⁽³⁾	270	720
8	150	110	110	295
	300	140	179	478
10	150	115	179	478
	300	160	270	720
12	150	120	179	478
	300	170	401	1069

(1) Torque values are recommended for low and intermediate strength bolting per ANSI B16.5 ¶5.3.2. Higher torques may be used with high strength bolting (ANSI B16.5 ¶5.3.1). In all cases the user must verify the selected bolting's ability to seat the joint under expected operating condition. Long thru-bolted joints generally require higher strength bolting and torque values than shorter flanged bolting depending on operating conditions.

(2) Lengths are based on ANSI B16.5 stud bolts and raised face ends.

(3) Lengths are for the shorter studs used in treaded holes. Refer General Assembly drawing for the quantities.

7. REMOVING VALVE FROM LINE

1. If an internal problem is suspected with the valve and disassembly is required, remove the valve from the line by proceeding as follows.

WARNING: Depressurize line to atmospheric pressure, drain all process fluids and decontaminate the valve (if caustic or hazardous materials are present). Failure to do so can cause serious injury. Make sure the valve is in closed condition.

2. Attach a hoist or some means to support the valve.
3. Remove line bolting. Do not attempt to pry line flanges apart by pushing or pulling on the valve or actuator.
4. Slide the valve carefully from the line. To avoid damage to the gasket surfaces, do not twist the valve.

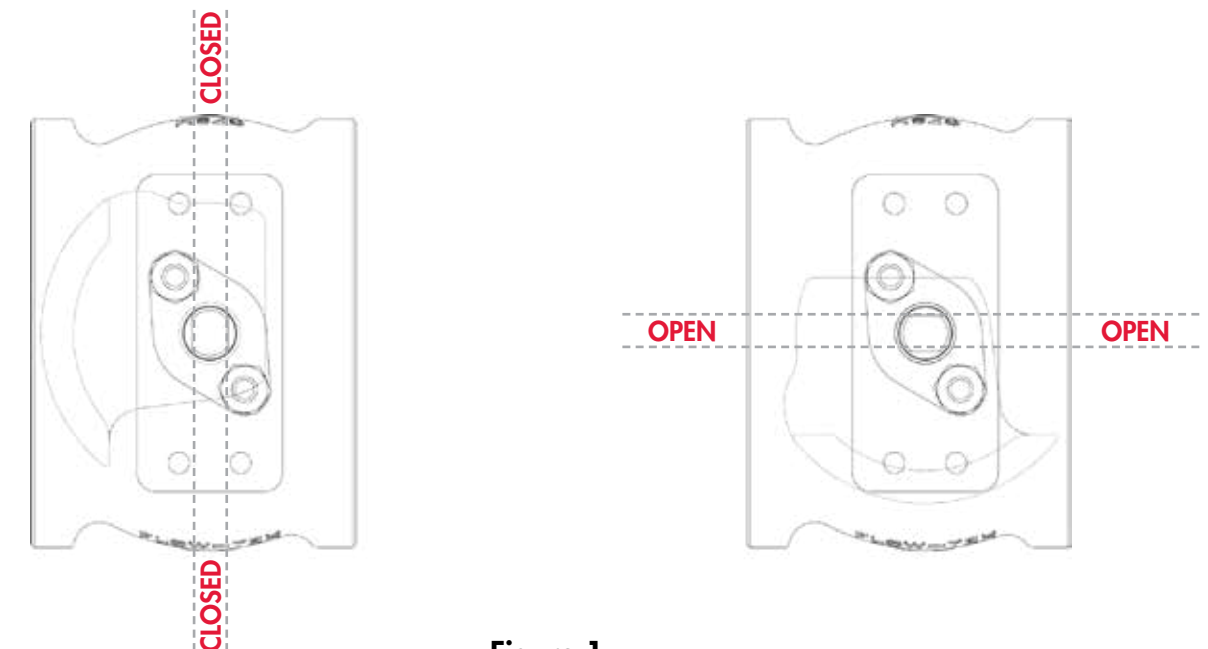

Figure 1

5. After the valve is completely removed from the line, slowly relieve air pressure from the actuator.

8. ACTUATOR

The valve closed and open position are indicated by the position of double "D" on the stem. Refer below figure.

If possible, install the valve so that the actuator can be disconnected without removing the valve from the piping.

The actuator must not touch the pipe line, because pipeline vibration may damage it or interfere with its operation. In some cases, for instance when a large-size actuator is used or when the pipe line vibrates heavily, supporting the actuator is recommended.

APPENDIX - A
CLASS 150/300

9. DISASSEMBLY AND REASSEMBLY

9.1 - Removing Actuator from Body

Refer to relevant actuator installation, operation, and maintenance instructions, and proceed.

- Support the actuator assembly before disconnecting it from the body assembly.
- Unbolt mounting bracket from body and lift actuator assembly off stem.

9.2 - Replacing the Seat

Refer to parts listing on pg. 12 & 13.

9.2.1 - Detaching the Seat

- The valve must be removed from the pipeline.

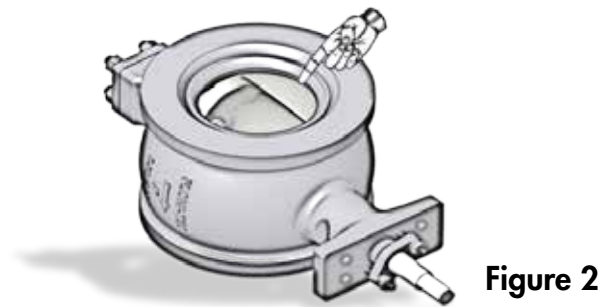

Figure 2

- Turn the segment (5) so that it does not touch the seat (2).
- 1" (DN25) – 4" (DN100) valves can be dismantled, as described in "Dismantling the valve" section to make the replacement of the seat easier.
- Tap the seat (2) with a soft spindle all around the circumference from the upstream side to make it fall into the body (1).
- Turn the valve and lift the seat (2) from the body (1) through the downstream flow port.

9.2.2 - Installing the Seat

Clean the flow port that houses the seat. Remove any burrs. Round off the edges using a fine abrasive paper and clean the flow port carefully, see below figure.

- Place the seat O-ring (4) on to the seat (2).



Figure 3

- Lubricate the flow port, seat (2) and O-ring (4) and the seat spring (3) with a volatile lubricant. Make sure that the lubricants are compatible with the medium.
- Place the seat spring (3) on the seat (2).
- When the valve is opened, the ends of the spring must be by the V-shaped opening.

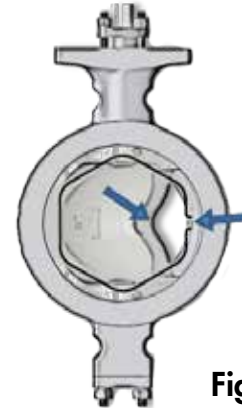

Figure 4

- Place the seat package into the body.

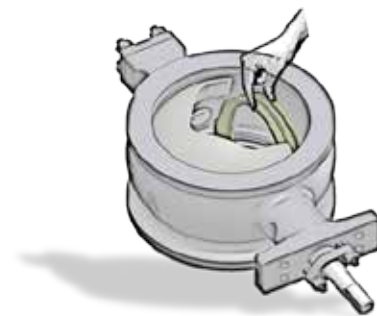

Figure 5

- Check that the spring angles extend to the control face.

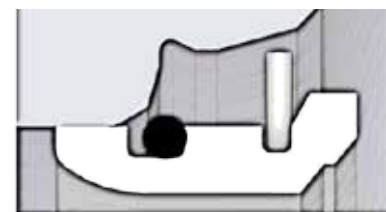

Figure 6

- Place a screwdriver on each visible spring angle one after the other and knock the spring into the groove.
- Turn the segment (5) 180° clockwise and knock the rest of the spring angles into the groove.
- Use a plastic spindle to ensure that the seat (2) is correctly placed and can move freely.



Figure 7

9.3 - Dismantling the Valve - See Pg. 10 diagrams

- Turn the valve into the closed position.
- Remove the gland retainer (15) by removing both packing nuts (18) and washers (17). Removing the studs (16) is not necessary
- Remove the post cover (20) by dismantling the nuts (23) and washers (22) and then pushing with Screwdriver.
- Drive the stem pin (10) and end post pin (11) into the center of the stem (8) and end post (9) until the outward end of the pin clears the segment (5). Be careful not to damage the stem or end post. The pins can then be punched out of the stem and end post when they are removed from the valve.
- Carefully remove post cover (20) and the gasket (19) and finally the end post (9). (Inserting a bolt in the jack screw hole, tapped in the post, will help in removing the post.)
- Remove the stem (8), along with gland ring (14), packing (13), and thrust washer (12) by pulling out through packing box side.

CAUTION: Take special care to not damage the splined end of stem (8) during disassembly.

- Remove the Segment
- Rotate the segment (5) inside the body (1) so the non-splined end of the segment (5) is toward the downstream port of the body (1) and remove the segment (5) straight out of the body (1) **(See diagram on pg. 10)**

CAUTION: Be extremely careful not to gall or scratch the sealing surface of the segment (5) when removing it from body (1). Scratches may later cause excessive leakage and seal wear.

- Remove the bearings (6 and 7) and clean the bearing spaces.
- Remove the seat (2) by pushing it evenly inside the body (1)

9.4 Inspection of Removed Parts

- Clean the removed parts
- See if the stem (8) and bearings (6 and 7) are damaged.
- Check if the sealing surface of the segment (5) and the seat (2) are damaged.
- If necessary, replace the parts with new.

9.5 Assembly

- Put the bearings (6 and 7) in their places.
- Position the segment (5) in the body (1) by lowering it, splined hole first, into the back of the body (1). Rotate the segment surface toward the front of the body so that the splined hole is toward the packing box

CAUTION: Be extremely careful not to gall or scratch the sealing surface of the segment (5) when replacing it in the body (1). Scratches may later cause excessive leakage and seal wear.

- Insert the stem (8) through the packing box bore, into the splined hole of segment (5).

Figure 8

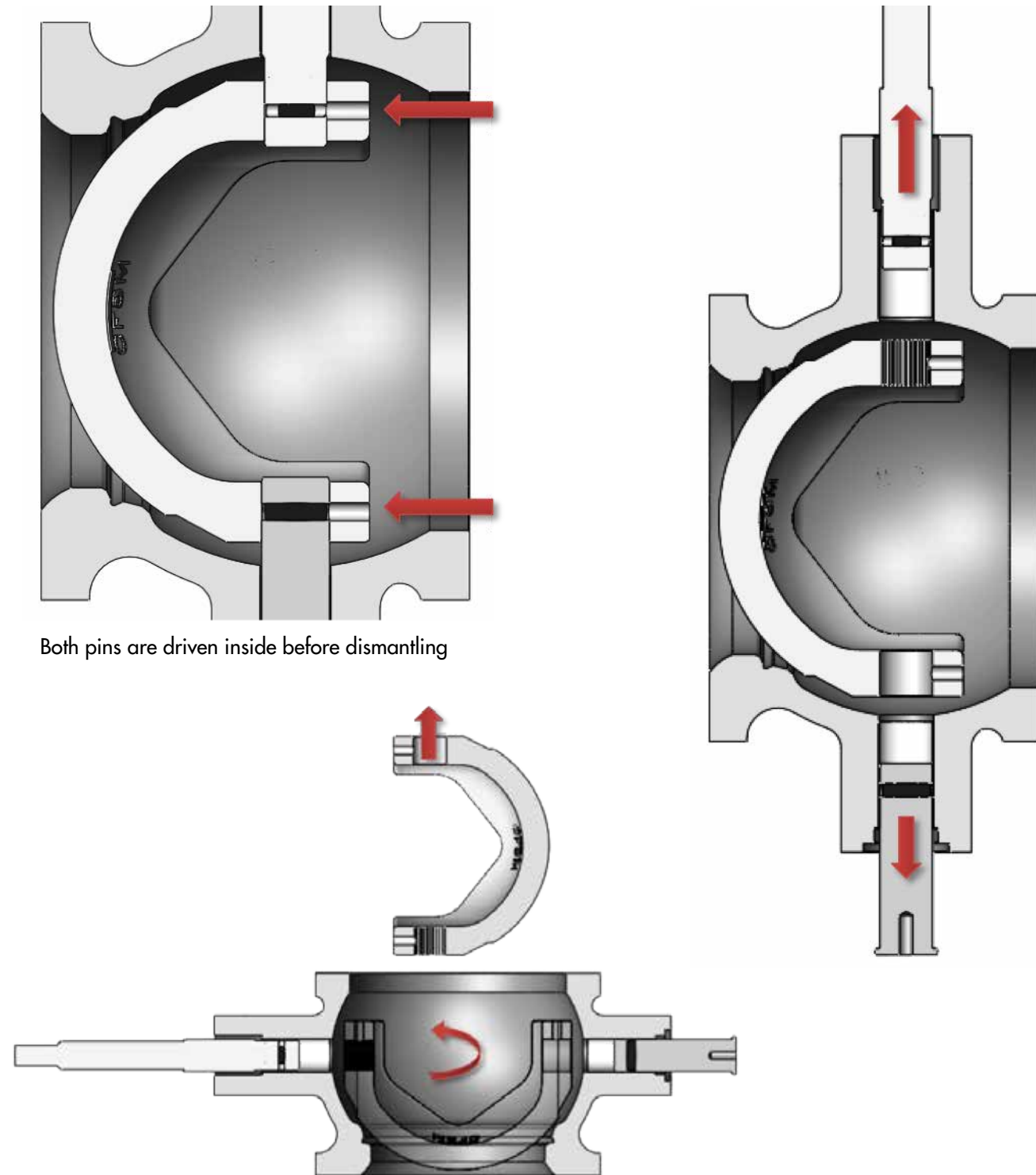

Both pins are driven inside before dismantling

- Position the stem (8) so that the pin hole in the stem (8) and Segment (5) are in alignment. (Stem flats on the top and pin holes are perpendicular to each other). Install the stem pin (10) and drive it firmly into place so that half is in the Segment (5) and half in the stem (8).
 - Insert the end post (9) through the out board end of the body (1). End post has a half circle mark on the end. Align this mark with the Segment (5). Install the end post pin (11) and drive it firmly into place so that half is in the Segment (5) and half is in the end post (9).
 - Install the post cover (20) with gasket (19) and tighten the nuts (23) as per Table-3.
 - Slide thrust washer (12), packing (13), and gland ring (14) over the double D end of the stem (8) and into packing box bore.
- NOTE:** Always use new packing whenever rebuilding the packing box.
- CAUTION:** Since the sealing on V-ring packing takes place at the feather edge, it is imperative to avoid damage to that edge.
- Reinstall the gland retainer (15), packing studs (16), packing washers (17) and packing nuts (18), tighten the packing nuts (18) just over finger-tight. Packing nuts should be tightened as necessary to prevent stem leakage.
- CAUTION:** Do not over tighten packing. This can cause excessive packing wear and high shaft friction, which may retard shaft rotation.
- **Mount the Seat (2) as explained in "Installing the Seat for Class 150 & 300 Design"**

9.6 Remounting the Actuator

Before mounting an actuator on the valve body (1), verify that the Segment (5) rotation matches the actuator rotation and complies with the air failure requirements. Procedure for mounting the actuator is as follows

- Bolt the Bracket (24) on to the body, if it's removed.
- Slide the entire actuator assembly onto the shaft. (Please refer to the actuator IOM for necessary adjustments on the assembling with valve for the lever adjustments for the clamped lever designs etc.)

ITEM #	Component
1	BODY
2	SEAT
3	SEAT SPRING
4	SEAT O-RING
5	SEGMENT
6	STEM BEARING
7	POST BEARING
8	STEM
9	END POST
10	STEM PIN
11	END POST PIN
12	THRUST WASHER
13	PACKING
14	GLAND RING
15	GLAND RETAINER
16	PACKING STUD
17	PACKING WASHER
18	PACKING NUT
19	GASKET
20	POST COVER
21	POST COVER STUD
22	POST COVER WASHER
23	POST COVER NUT
24	MOUNTING BRACKET
25	BRACKET WASHER
26	BRACKET SCREW

Figure 9

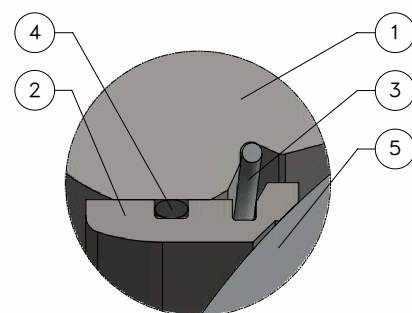
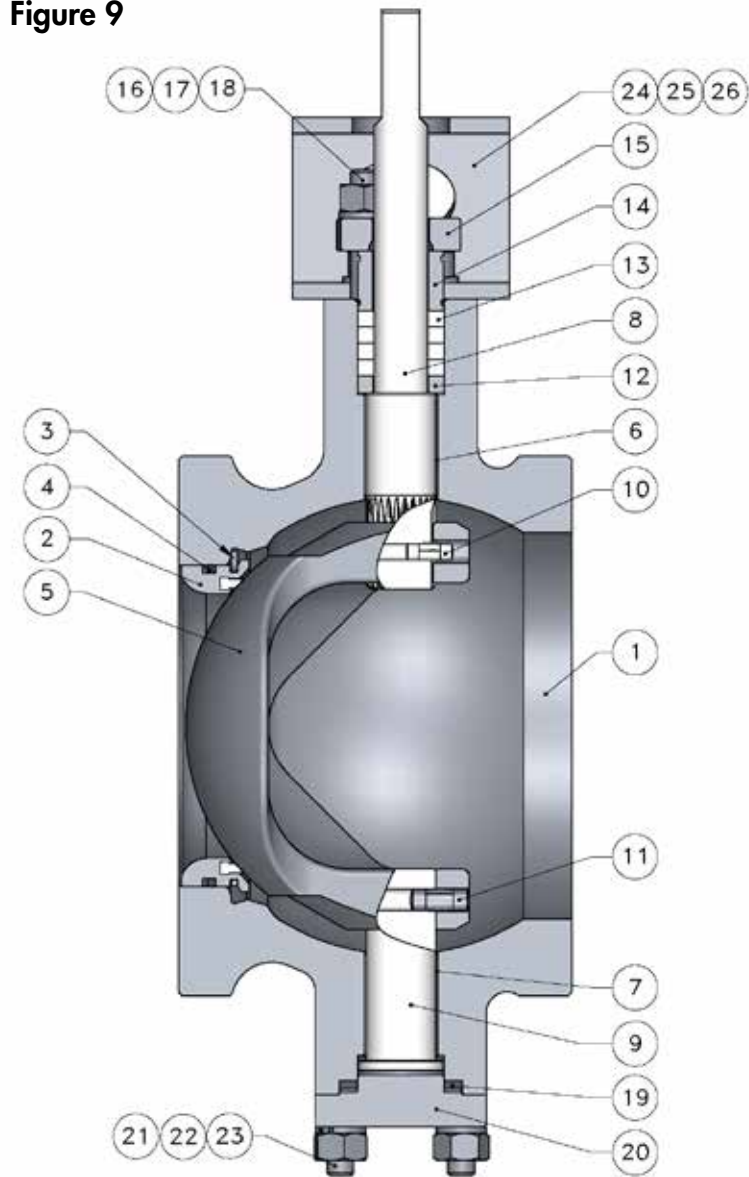

METAL SEAT

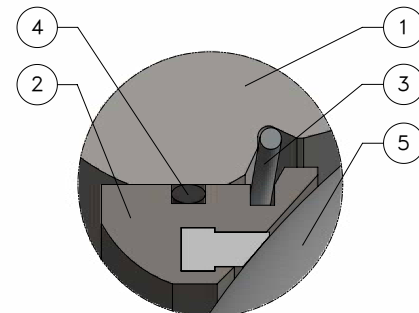

SOFT SEAT

Figure 10

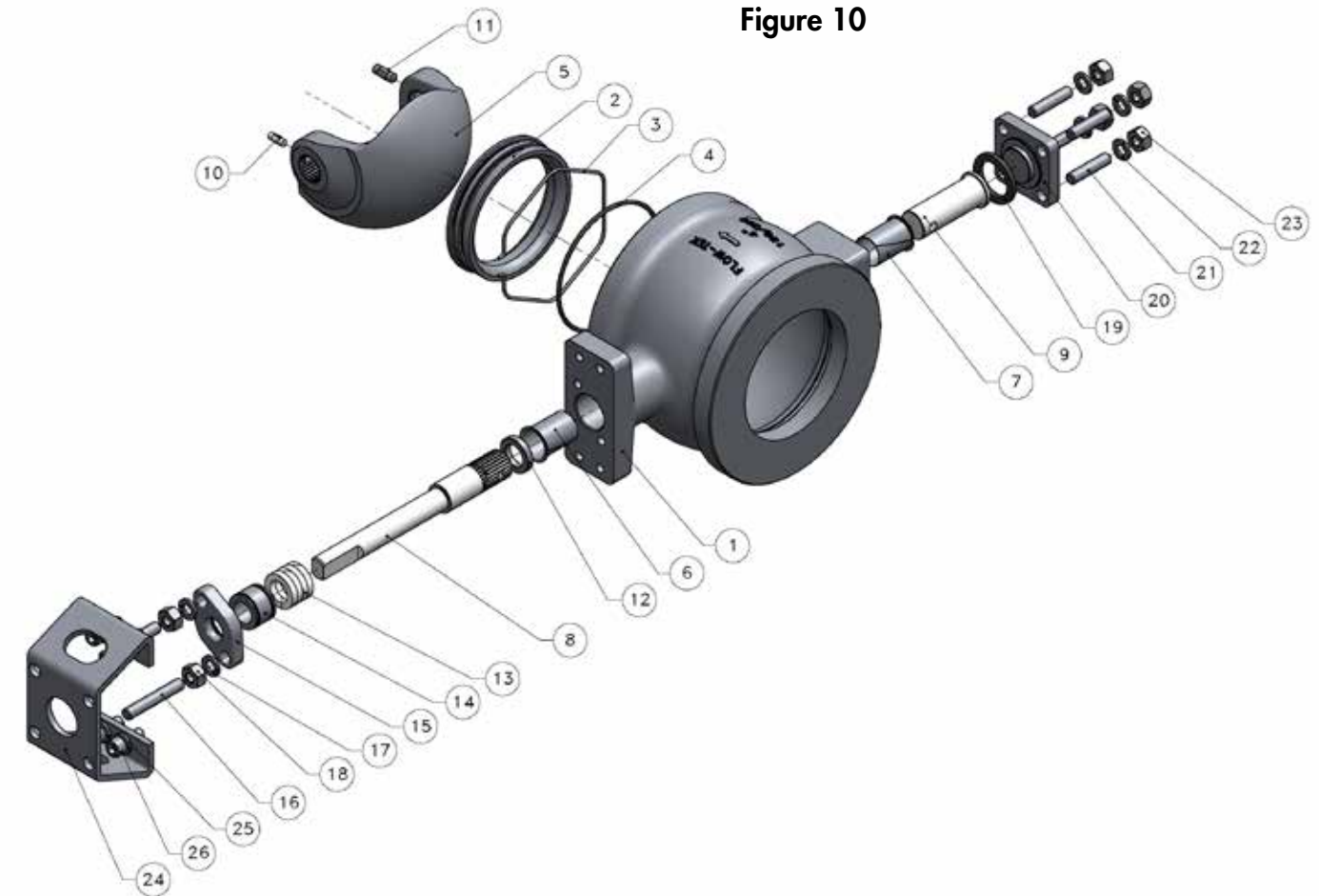

ITEM #	Component
1	BODY
2	SEAT
3	SEAT SPRING
4	SEAT O-RING
5	SEGMENT
6	STEM BEARING
7	POST BEARING
8	STEM
9	END POST
10	STEM PIN
11	END POST PIN
12	THRUST WASHER
13	PACKING SET

ITEM #	Component
14	GLAND RING
15	GLAND RETAINER
16	PACKING STUD
17	PACKING WASHER
18	PACKING NUT
19	GASKET
20	POST COVER
21	POST COVER STUD
22	POST COVER WASHER
23	POST COVER NUT
24	MOUNTING BRACKET
25	BRACKET WASHER
26	BRACKET SCREW

**APPENDIX - B
CLASS 600**

11. DISASSEMBLY AND REASSEMBLY

11.1 Removing Actuator from Body

1. Refer to relevant actuator installation, operation, and maintenance instructions, and proceed.
2. Support the actuator assembly before disconnecting it from the body assembly.
3. Remove mounting bracket bolts from body and lift actuator assembly off stem.

11.2 Dismantling the Valve

Refer to parts listing on pg. 18 & 19.

1. Turn the valve into the closed position and remove from pipeline.
2. Place the valve on a flat surface with seat retainer (2A) facing up.
3. Loosen the screwed-in seat retainer (2A) by turning it counterclockwise and removing it from the body (1) along with the retainer O-rings (4A, 4B). (A special cross-wrench tool may be ordered from the factory).

4. Once the seat retainer is removed, remove the seat (2), wave springs (3) and shims (3A) along with the seat O-ring (4).
5. Remove the gland retainer (15) by removing both packing nuts (18) (Removing the packing studs (16) is not necessary).
6. Remove the post cover (20) by dismantling the post cover nuts (23) and pushing with Screwdriver.
7. Drive both the stem and end post pins(10, 11) into the center of the stem and post until the outward end of the pin clears the segment (5). Be careful not to damage the stem or post. The pins can then be punched out of the stem and post when they are removed from the valve. Carefully remove post cove (20) and the gasket (19) and finally the post (9). (Inserting a bolt in the jack screw hole, tapped in the post, will help in removing the post).
8. Remove the stem (8) by pushing it out through the post end of the body.

CAUTION: Take special care to not damage the splined end of valve stem during disassembly.

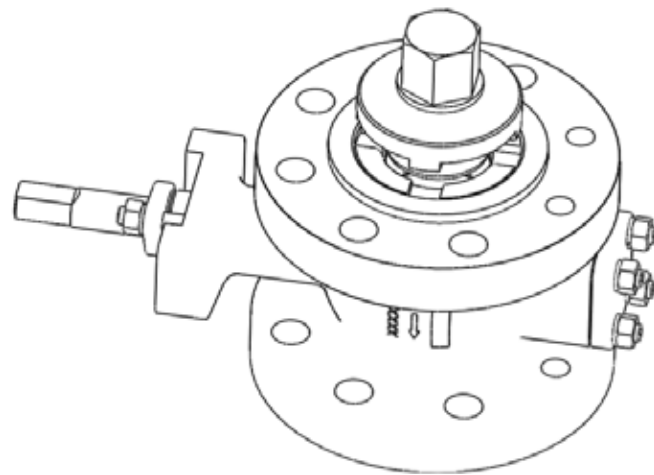
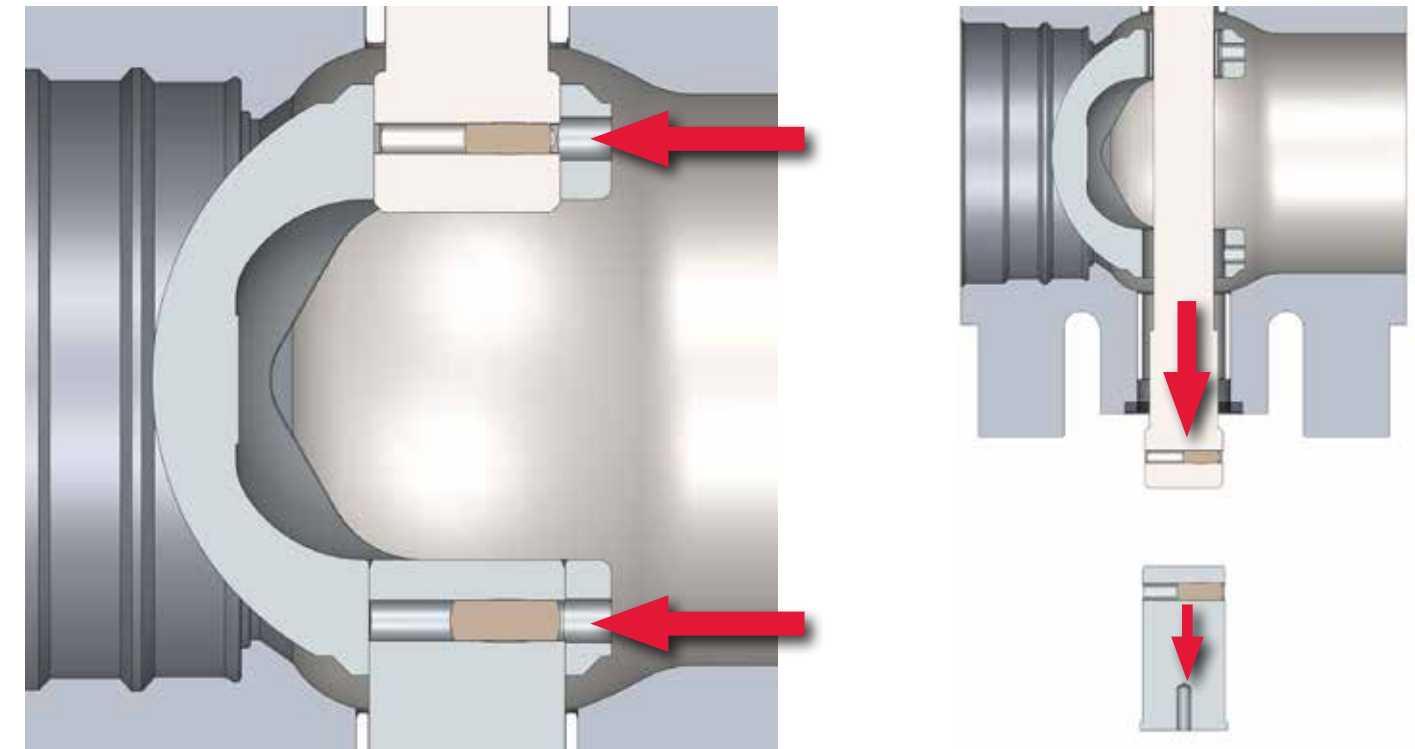

Figure 11
Removing the retainer with special tool

Figure 12



Both pins are driven inside before dismantling

9. Rotate the segment (5) inside the body so the non-splined end of the segment is toward the downstream port of the valve and remove the segment straight out of the body.

CAUTION: Be extremely careful not to gall or scratch the sealing surface of the segment when removing it from body. Scratches may later cause excessive leakage and seal wear.

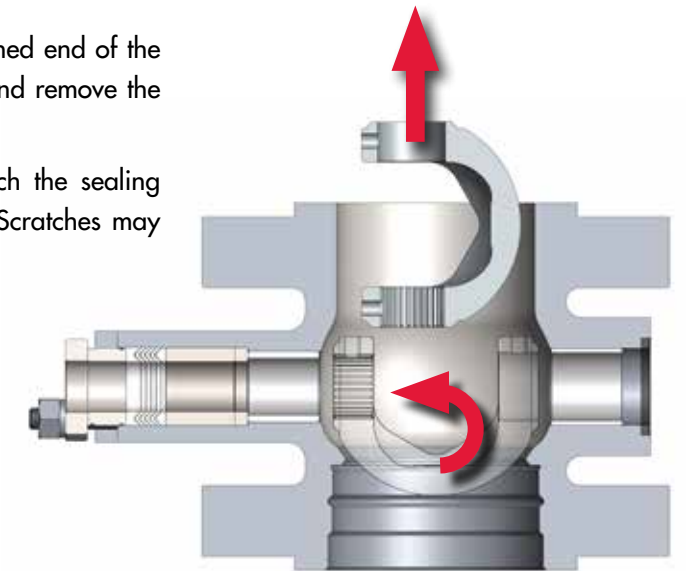

12. Push packing (13) and bearings (6, 7) out of the body using a soft metal (bronze) dowel with the appropriate diameter. Push packing out of the body from the center of the valve.

11.3 - Reassembling the Valve

To reassemble the body subassembly, refer to the Parts Diagram.

1. Clean all parts and replace all O-rings and soft seals.
2. Check the segment (5) sealing surface to make sure it is smooth and free of scoring and scratches.

CAUTION: Damaged or dirty seal surfaces can cause excessive seat wear and high torque requirements. Damaged segment should be replaced.

3. Inspect the stem (8) and end post (9) for scratches or galled surfaces. If damage exists, replace the stem or contact the factory representative.

NOTE: Segment and stem are interchangeable. Replacing the segment does not require replacing the stem.

4. Using a press to install new bearings in the body is recommended. (Optional post/bearing tool is available from the factory - See Table 4 on page 17) when correctly installed, the ends of the body bearings (6, 7) should be flush with the inside of the body.

5. Position the segment (5) in the body by lowering it, splined hole first, into the back of the body. Rotate the segment surface toward the front of the body so that the splined hole is toward the packing box.

CAUTION: Be extremely careful not to gall or scratch the sealing surface of the segment when replacing it in the body. Scratches may later cause excessive leakage and seal wear.

6. Insert the stem (8) through the post end of body and through the splined hole of the segment into the packing box.
7. Position the stem so that the pin hole in the stem (8) and

Segment (5) are in alignment. (Stem (8) across flat on the top and pin holes are perpendicular to each other). Install the stem pin (10) and drive it firmly into place so that half is in the Segment (5) and half in the stem (8).

8. Insert the end post (9) into the body. Posts have a half circle mark on the end. Align this mark with the Segment. Install the end post pin (11) and drive it firmly into place so that half is in the Segment and half is in the post.
9. Install the post cover (20) with gasket (19), tighten the nuts (23) to the required torque per Table-3.
10. Slide thrust washer (12), packing spacer (13A), packing (13), and gland ring (14) over the double D end of the stem and into packing box bore.

NOTE: Always use new packing whenever rebuilding the packing box.

CAUTION: Since the sealing on V-ring packing takes place at the feather edge, it is imperative to avoid damage to that edge.

11. Reinstall the gland retainer (15) and packing nuts (18) and leave loose.

CAUTION: Do not over tighten packing. This can cause excessive packing wear and stem friction, which may impede stem rotation.

12. Place the valve on a flat surface with the threaded (retainer) port facing up and pull the stem (8) toward the actuator until it is fully against the thrust washer (12).

13. Make certain the segment surface facing up and position the segment as close as possible in the center of the body's inside diameter. (The pinned connection between the segment and stem is not a tight connection. The design includes a considerable amount of axial play between the segment and stem.)

14. Lubricate the seat O-ring (4) and install into the seat (2).

15. Lubricate the seat retainer O-ring (4A) and install into the Seat Retainer (2A).

16. Lubricate the mating surfaces between the seat (2) and seat retainer (2A).

17. Place Wave springs (3) & shim (3A) set in the seat retainer.

18. Place the seat (2) into seat retainer (2A), so the seat is resting on the shims and wave springs.

19. For metal seat, lubricate the contact surfaces between the seat and segment.

20. Replace the O-rings (4B) in the seat retainer (2A) (except on high temperature valves, which do not use O-rings). Refer to Figure 13. Lubricate the seat retainer threads and O-rings and reinstall the retainer in the body. Torque the seat retainer according to Table 2.

21. After the seat retainer is tightened, tighten the packing nuts (18) just over finger-tight. Packing nuts (18) should

be tightened as necessary to prevent stem leakage.

CAUTION: Do not over tighten packing. This can cause excessive packing wear and high stem friction, which may retard stem rotation.

11.4 Remounting the Actuator

1. Before mounting an actuator on the valve body, verify that the Segment rotation matches the actuator rotation and complies with the air/signal failure requirements. Procedure for mounting the actuator is as follows.

2. Bolt the Bracket on to the body, if it is removed.

3. Slide the entire actuator assembly onto the stem by ensuring the desired actuator orientation. (Please refer to the actuator IOM for necessary adjustments on the assembling with valve).

4. Tighten the actuator mounting bolts.

5. Install valve in pipe line as outlined in Section 4.

Table 2: Retainer Torques

Valve Size (inches)	Torque Value (N-m)
1, 1.5, 2	200-240
3	340-410
4, 6	750-820

Table 3: Lubricated Screw Tightening Torques

Stud Size	A193-B7 & B7M	A193-B8
1/4"-20 UNC	5 Nm	2 Nm
5/16"-18 UNC	10 Nm	4.5 Nm
3/8"-16 UNC	18 Nm	8 Nm

Table 4: Assembly Tools (Optional upon request)

Valve Size	Retainer Tool Part No.	Stem Bearing Press Tool Part No.	Post Bearing Press Tool Part No.
1" (DN 25)	9N-0000-00466	9N-0000-00471	9N-0000-00476
1.5" (DN 40)	9N-0000-00467	9N-0000-00472	9N-0000-00477
2" (DN 50)	9N-0000-00468	9N-0000-00473	9N-0000-00478
3" (DN 80)	9N-0000-00445	9N-0000-00448	9N-0000-00449
4" (DN 100)	9N-0000-00469	9N-0000-00474	9N-0000-00479
6" (DN 150)	9N-0000-00470	9N-0000-00475	9N-0000-00480

ITEM #	Component
1	BODY
2	SEAT
2A	SEAT RETAINER
3	SEAT SPRING
3A	SEAT SHIM
4	SEAT O-RING
4A	O-RING (SEAT-RETAINER)
4B	O-RING (BODY-RETAINER)
5	SEGMENT
6	STEM BEARING
7	POST BEARING
8	STEM
9	END POST
10	STEM PIN
11	END POST PIN
12	THRUST WASHER
13	PACKING SET
13A	PACKING SPACER
14	GLAND RING
15	GLAND RETAINER
16	PACKING STUD
17	PACKING WASHER
18	PACKING NUT
19	GASKET
20	POST COVER
21	POST COVER STUD
22	POST COVER WASHER
23	POST COVER NUT
24	MOUNTING BRACKET
25	BRACKET WASHER
26	BRACKET SCREW

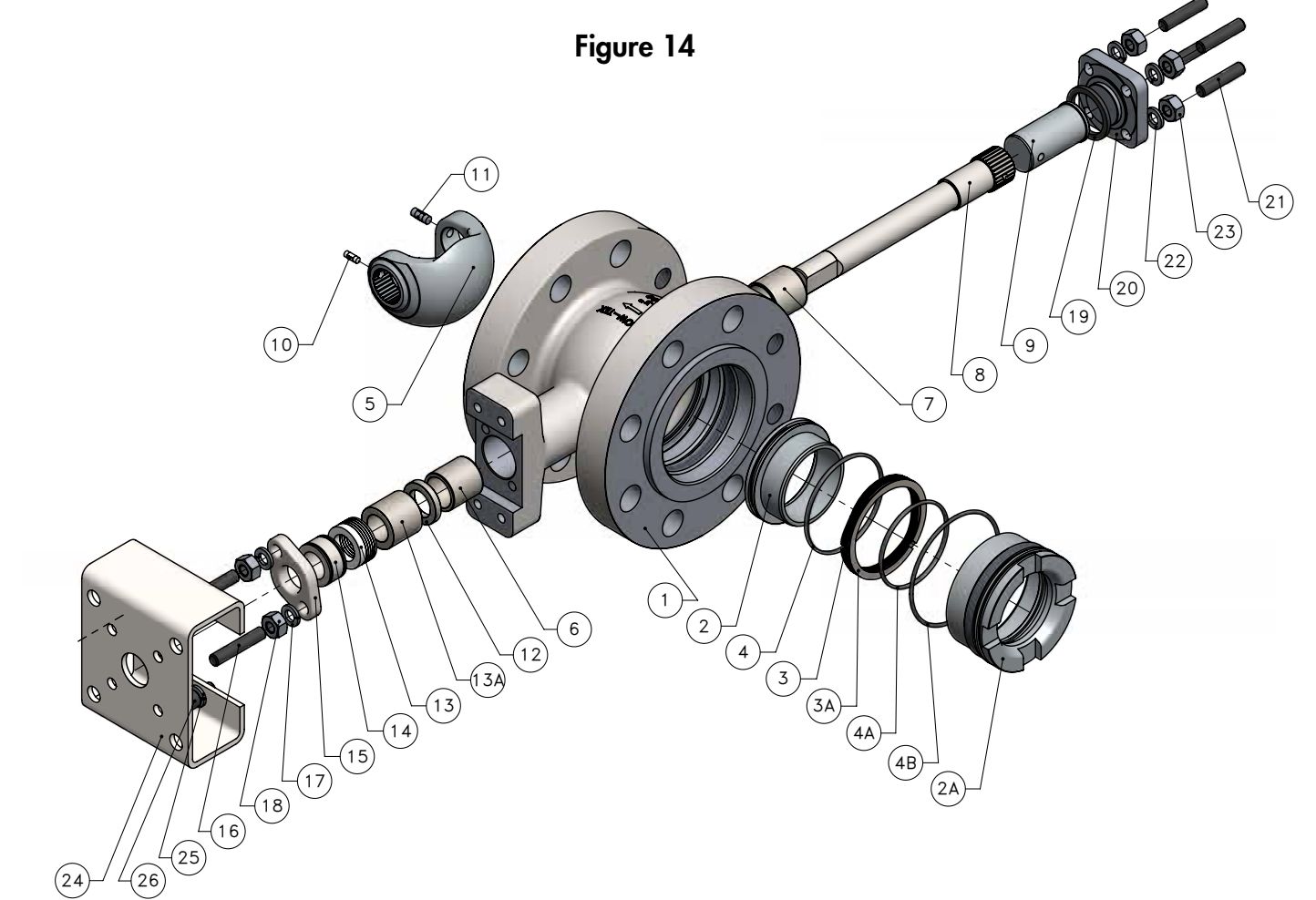
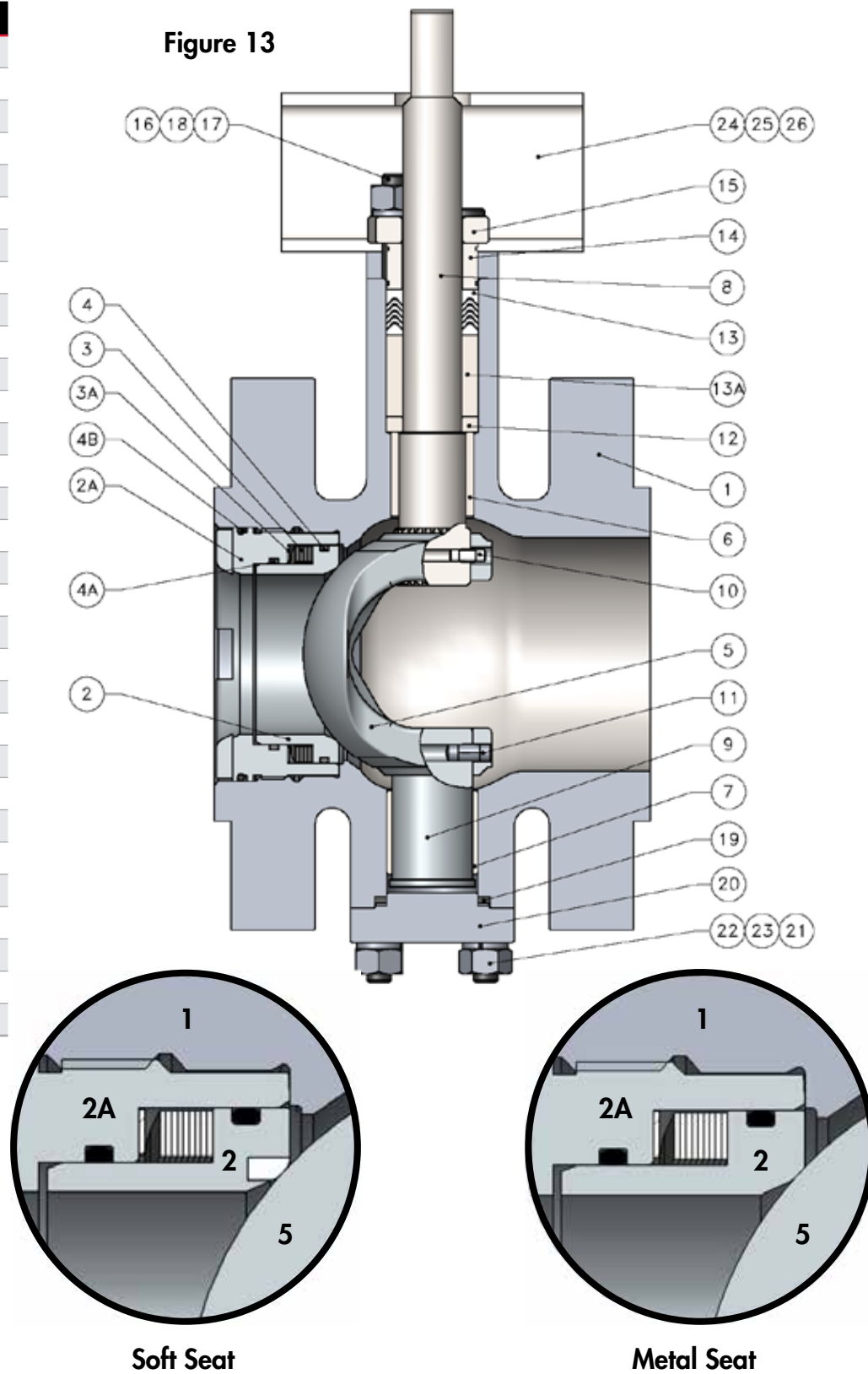

ITEM #	Component
1	BODY
2	SEAT
2A	SEAT RETAINER
3	SEAT SPRING
3A	SEAT SHIM
4	SEAT O-RING
4A	O-RING (SEAT-RETAINER)
4B	O-RING (BODY-RETAINER)
5	SEGMENT
6	STEM BEARING
7	POST BEARING
8	STEM
9	END POST
10	STEM PIN
11	END POST PIN
12	THRUST WASHER

ITEM #	Component
13	PACKING SET
13A	PACKING SPACER
14	GLAND RING
15	GLAND RETAINER
16	PACKING STUD
17	PACKING WASHER
18	PACKING NUT
19	GASKET
20	POST COVER
21	POST COVER STUD
22	POST COVER WASHER
23	POST COVER NUT
24	MOUNTING BRACKET
25	BRACKET WASHER
26	BRACKET SCREW